



PHASE



ALPHA



PHASE CONVERTING | 115 V & 230 V | CONSTANT PRESSURE VFD
NEMA 3R OUTDOOR ENCLOSURE | 2-5 HP

All content within this publication is protected by United States copyright law and international copyright treaties and agreements. No part of this material may be copied, reproduced, distributed, republished, downloaded, displayed, posted, or transmitted in any form or by any means—whether electronic, mechanical, photocopying, recording, or otherwise—without prior written permission from Phase Technologies.

You are permitted to download a single copy of this publication from www.phasetechnologies.com

for your personal, non-commercial, internal use only. This constitutes a single-copy, single-use license and does not transfer ownership of the material. You may not modify, use for commercial purposes, display publicly, or remove any copyright or proprietary notices from the material.

The information provided in this publication is for reference only and is subject to change without notice. While efforts have been made to ensure the accuracy of this manual at the time of release, ongoing product enhancements and updates may render it obsolete. Visit www.phasetechnologies.com for the most current version.

This publication is provided “as is,” without warranties of any kind, either express or implied. To the maximum extent permitted by applicable law, Phase Technologies disclaims all warranties, including but not limited to implied warranties of merchantability, fitness for a particular purpose, and non-infringement of intellectual property rights or other violations. Phase Technologies makes no representations regarding the accuracy, completeness, or reliability of the information contained herein.

Under no circumstances shall Phase Technologies be liable for any direct, indirect, incidental, consequential, or special damages—including but not limited to loss of data, property damage, or expenses—arising from the installation, operation, use, or maintenance of the products based on the information in this manual, even if advised of the possibility of such damages.

1 Safety Instructions and Warnings

To ensure the safe and reliable operation of Phase Technologies variable frequency drives (VFDs), it is essential to read and understand this manual thoroughly. Please review all warning labels on the equipment prior to installation. Follow all instructions precisely, and keep this manual accessible for future reference.

1.1 Definitions of Warning Signs and Symbols

- ⚠ **CAUTION:** Indicates a potentially hazardous situation that may result in minor injury or damage to the equipment.
 - ⚠ **WARNING:** Indicates a potentially hazardous situation that could result in serious injury or death.
 - ⚡ **HIGH VOLTAGE:** Indicates the presence of high voltage, which can result in serious injury or death. Use extreme caution and follow all instructions carefully.
-

1.2 General Safety Warnings

1.2.1 Critical Safety Warnings and Cautions

⚠ **WARNING: Risk of Electric Shock**

Before servicing, **de-energize the unit** by disconnecting all incoming power sources. Then wait the full discharge time specified on the drive's warning label to ensure internal components are safe to handle.

⚡ **HIGH VOLTAGE HAZARD**

This equipment operates at dangerous line voltages. Contact with high voltage can result in **serious injury or death**. Installation must be performed **only by trained, licensed, and qualified personnel**. Follow all instructions precisely and observe every safety warning.

⚠ **WARNING: Qualified Personnel Required**

Only personnel who are trained, experienced, and familiar with the specific equipment and the risks associated with high-voltage systems should perform installation or servicing.

⚠ **WARNING: Code Compliance**

Installation must comply with the **National Electrical Code (NEC)** and all **applicable local electrical codes**. Noncompliance may result in electrical shock, fire, or equipment damage.

⚠ **CAUTION: AUX Terminal Usage**

The **AUX1 through AUX3** terminals are galvanically isolated and carry a potential difference of approximately **5V**. Do **not** apply external voltage. These terminals are intended for **dry contact use only**.

⚠ CAUTION: External Safety Components

Phase Technologies, LLC does **not** provide circuit breakers, fuses, grounding circuits, disconnects, or other external safety components. The selection, installation, and maintenance of these components are **the responsibility of the end user** and must meet all applicable codes and safety standards.

1.2.2 Installation-Specific Cautions

⚠ CAUTION: AUX1–AUX4

These terminals are galvanically isolated and carry approximately 5V potential between them. Do not apply external voltage; dry contact use only.

⚠ CAUTION: External Safety Equipment

Circuit breakers, fuses, grounding, disconnects, and other protective devices are not provided by Phase Technologies. These must be installed by the end user and meet all code requirements.

⚠ CAUTION: Long Motor Leads

Long leads, particularly in deep-well pump installations, can cause voltage spikes due to reflected harmonics. For leads over 50 feet, a sine wave filter may be necessary. Consult the factory or a qualified expert on motor protection filters.

⚠ CAUTION: Ventilation Clearance

Ensure sufficient clearance for airflow. Inadequate ventilation can cause overheating, damage, or fire.

1.2.3 Electrical Installation Requirements

⚠ WARNING: Short-Circuit Rating

Suitable for circuits delivering no more than 25 kA RMS symmetrical amperes at 240 VAC.

⚠ WARNING: Wire Ratings

All field wiring and motor circuit wires must be rated for at least 60 °C and suitable for Class 1 circuits.

⚠ WARNING: Input Power Requirements

For 230V input models, power must be supplied by a qualified electrician using a nominal 230V circuit with adequate capacity. Branch circuit protection must be provided using appropriately rated fuses or circuit breakers (see Table 4).

⚠ WARNING: Short Circuit Protection

These devices include solid-state short-circuit protection. However, branch circuit protection must still be provided in accordance with NEC and local codes.

⚡ CAUTION: Wire Type and Voltage Drop

Use 600V vinyl-sheathed copper wire (or equivalent). Consider voltage drop based on wire length and gauge during installation.

⚡ CAUTION: Terminal Torque and Wire Size

Follow torque specifications and wire gauge limits as listed in Table 4. Use only the wire sizes recommended for input/output terminals.

⚡ CAUTION: Wiring Best Practices

- Do not allow bare wire to contact metal surfaces.
- Never connect AC main power to output terminals U, V, and W.

⚠ WARNING: Automatic Motor Restart

The motor may automatically restart after a fault is cleared. Ensure power is fully disconnected before approaching or servicing the unit to avoid serious injury.

⚠ WARNING: Ingesting coin cell batteries can cause severe internal injuries or death.

Store batteries out of reach of children, seek immediate medical attention if ingestion occurs, and follow any other consensus medical advice.

⚡ CAUTION: Use caution when applying power to the main input terminals of the unit.

If the drive is programmed to allow automatic restarts, the drive will initialize in AUTO mode and the motor load may start as soon as the drive is energized.

⚡ CAUTION: The AC motor load must be connected directly to the output terminals of the drive.

Do not install relays, disconnect switches, or wire nuts between the drive and the motor load.

⚡ CAUTION: Before the motor is connected to the output terminals, check all output lines for line-to-ground faults using a megger.

There is a direct path through the drive circuitry for ground fault currents that can be triggered when power is applied to the input terminals, even though the output switches are not activated. These currents can cause serious damage to drive circuitry and are not covered under warranty.

⚡ CAUTION: Before touching any printed circuit board, place a hand on a bare metal surface of the unit to discharge any static electricity.

Electrostatic discharge (ESD) can damage printed circuits and their components.

⚡ CAUTION: When the parameter, 1.2.1 ENABLE RESTARTS, is set to YES, the drive will energize in AUTO mode.

The motor load may automatically run as soon as the drive is energized. To stop the motor, push the STOP/OFF key until the display indicates MANUAL or OFF, or open AUX1 or AUX2. The RUN and STOP keys only work when in MAN mode. Refer to the section on Keypad and Display for instructions on operating the keypad.

⚡ CAUTION: Operating the system in MANUAL mode on the keypad overrides remote signals from any remote controls.

Operating the system in this mode may lead to dangerous pressures in closed plumbing systems.

Contents

1 Safety Instructions and Warnings	3
1.1 Definitions of Warning Signs and Symbols.....	3
1.2 General Safety Warnings	3
1.2.1 Critical Safety Warnings and Cautions	3
1.2.2 Installation-Specific Cautions	4
1.2.3 Electrical Installation Requirements	4
2 Introduction	9
3 Models & Ratings	10
3.1 Specifications	10
3.2 Model Ratings	10
3.3 Model Nomenclature	11
3.4 Derating at High Elevations.....	11
3.5 Dimensional Drawing	12
4 Installation	13
4.1 Mounting.....	13
4.2 Installing Power Cables	15
4.3 Generator Power.....	16
4.4 Output Filters	17
4.5 Control Terminals.....	17
5 Keypad & Display	23
5.1 Using the Keypad and Display.....	23
6 Main Menu Parameters	26
6.1 Change Parameter Values.....	27
6.2 Read Measured Values	27
6.3 Read Timers.....	28

6.4 Restart Log	29
6.5 Fault Log.....	30
6.6 Clear Memory	30
6.7 Setup Wizards	30
6.8 Changing Parameter Values	34
6.9 Restore Default Parameter Settings	34
6.10 Auto Restarts.....	34
6.11 All Parameters List	35
6.12 Changed Parameter List.....	35
6.13 File System	35
6.14 Menu Structure Overview (Tree).....	39
6.15 Parameter Tables	41
7 Operation & Control Methods	54
7.1 Commissioning the Unit.....	54
7.2 VFD Setup Procedure	54
7.3 Ground Fault Sensitivity.....	55
7.4 Motor Overload Protection.....	55
7.5 System Configuration.....	56
7.6 Start-Up and Shut-Down Ramp Times	59
7.7 Motor Control Methods (V/f vs. Torque Control).....	60
8 Constant Pressure Control & Perfect Pressure	62
8.1 Control Principles of Constant Pressure Systems	62
8.2 Preventing Short Cycling	62
8.3 Adjusting Auto Sleep Settings	63
8.4 Adjusting PID Settings	63
8.5 Adjusting ON/OFF Cycle Timers	64

8.6 Adjusting Allowable Starts by Time	64
8.7 Emergency Over-Pressure Limit Switch	64
8.8 PerfectPressure™ Setup – Analog Constant Pressure	65
8.9 Analog Constant Pressure Systems.....	66
8.10 Pre-Charge Mode	67
8.11 Lead/Lag Pump Control.....	68
8.12 Duplex / Multiplex Control.....	69
8.13 De-Scale/De-Ragging (Pump Clean Out) Function	73
9 Troubleshooting	75
9.1 Fault Codes.....	75
9.2 Clearing a Fault.....	75
9.3 Fault Log	78
10 Maintenance	79
11 Warranty Policy	80
12 Appendix A – Constant Pressure Wizard	81
13 Appendix B – System Configuration Wizards	82
14 Appendix C – Lead/Lag Set-Up Guide	92
15 Appendix D – Multiplex Over Modbus Setup Guide	93
16 Appendix E – Troubleshooting: Transducers	95

2 Introduction

Phase Technologies' variable frequency drives (VFDs) are inverter-based systems that convert single- or three-phase AC input power into a variable frequency three-phase output, enabling precise speed control of AC motors. These drives combine advanced motor control capabilities with an intuitive, user-friendly interface for efficient and reliable operation.

The following block diagrams demonstrate how the drives convert incoming AC power to DC, then utilize an inverter module to generate three-phase variable voltage and frequency output to control the speed of a motor.

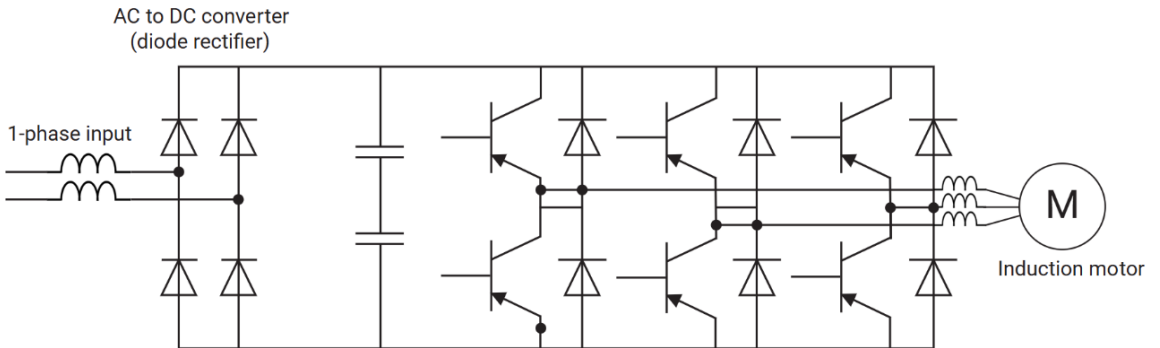

Figure 1 – Alpha Drive Block Diagram

3 Models & Ratings

3.1 Specifications

Table 1 – Alpha Drive Specifications

Specs	Range
Operating Temperature	-20°C – 55°C (-4°F – 131°F)
Storage Temperature	-40°C – 60°C (-40°F – 140°F)
Enclosure	NEMA Type 3R
Altitude	Derate by 1% for every 400 ft above 3,300 above sea level
Input Voltage	1-phase, 115 V, 230V, 460 V
Input Voltage Range	AD0xxR: 90 – 160 V, 180 – 260 V AD4xxR: 430 – 520 V
Input Frequency	50/60 Hz (1-phase)
Output Voltage	1-phase or 3-phase, Equal to Input
Output Frequency	5 - 120 Hz
Switching Frequency	2 - 8 kHz
Short Circuit Current Rating	5 kA RMS symmetrical Amperes
Efficiency	> 98%
Certification	UL 61800-5-1 CSA C22.2 No. 274-17

3.2 Model Ratings

Table 2 – Ratings

Model Number	HP Rating	Input Voltage	Motor Type	Rated Input Current (A)	Rated Output Current (A)
AD002R	2	115 V / 230 V	1- & 3-Phase	20	9
AD003R	3	115 V / 230 V	1- & 3-Phase	30	12
AD005R	5	115 V / 230 V	1- & 3-Phase	47	20
AD007R*	7.5	115 V / 230 V	1-* & 3-Phase	73	31
AD402R	2	460 V	1- & 3-Phase	10	4
AD403R	3	460 V	1- & 3-Phase	13	5.4
AD405R	5	460 V	1- & 3-Phase	22	9
AD407R	7.5	460 V	1- & 3-Phase	31	13
AD410R	10	460 V	1- & 3-Phase	43	18

* - AD007R will not run two-wire motors

3.3 Model Nomenclature

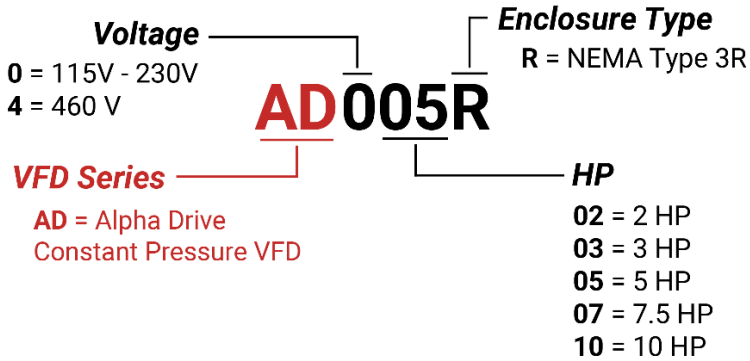

Figure 2 – Alpha Drive Nomenclature

3.4 Derating at High Elevations

Peripheral cooling components of the Alpha Drives operate at decreased effectiveness at higher elevations. At elevations of 3,300 feet (1,000 m) and lower, the drive can reach its full rated current. Current must be derated by 1% for every 400 feet above 3,300 ft. See **Figure 3** for details.

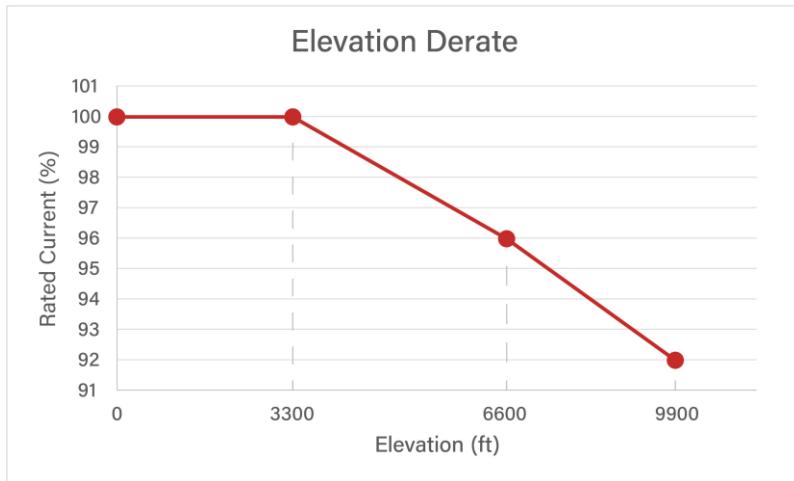

Figure 3 – Elevation Derate Chart

3.5 Dimensional Drawing

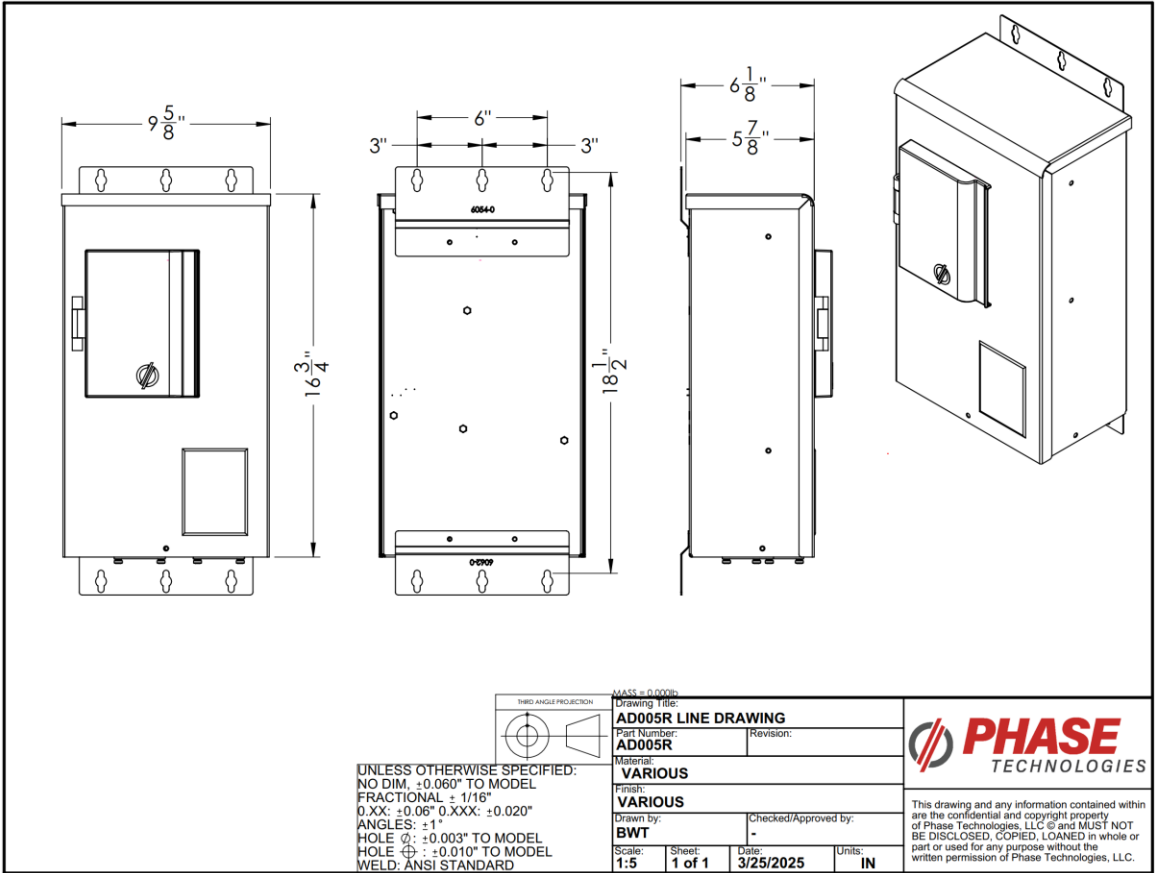

Figure 4 – Alpha Drive Line Drawing

4 Installation

4.1 Mounting

- The drive must be mounted in an upright position with adequate clearance for cooling and maintenance access. The mounting surface must be sturdy, non-flammable, and capable of bearing the weight of the unit. Fasten the unit to the mounting surface using screws or bolts of an appropriate size through the holes on the mounting brackets. Lifting hooks are provided on the top of some enclosures.
- To allow for proper cooling and air circulation around the enclosure, maintain minimum clearances depicted in **Figure 5**. The drives are cooled by fans with ventilation openings on the bottom of the enclosure. The surface around the enclosure should be non-flammable material and clear of obstacles. Locate the drawing in **Section 3.5** for dimensions and mounting hole locations.

⚠ CAUTION: Failure to maintain adequate clearance may lead to overheating of the unit and cause damage or fire. Obstructions blocking intake fans can damage fans.

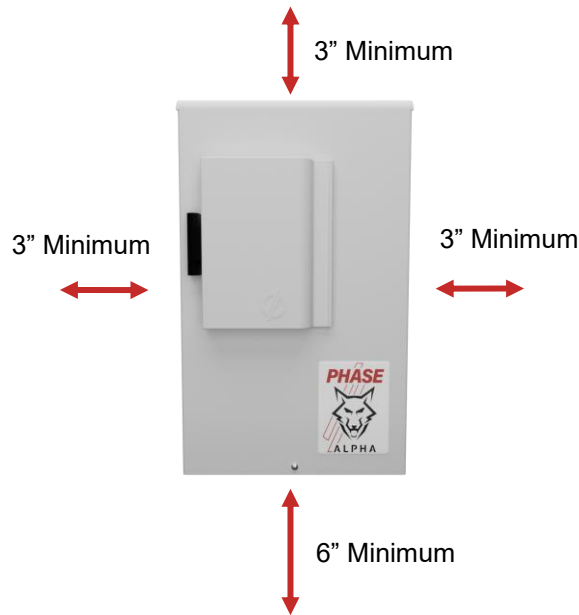

Figure 5 – Minimum Clearance

Ambient Temperature Rating

- Alpha Drives are intended for use in ambient temperatures of up to 55°C (131°F).

General Wiring Considerations

Table 3 – Power Terminal Descriptions

Terminal Name	Description
L1, L2 (Line)	Input Power Terminals
U	3W 1-Phase Motor Start Winding Output
V, W	2W, 3W 1-Phase Motor Output
U, V, W (Load)	3-Phase Motor Output
GND	Ground Lug

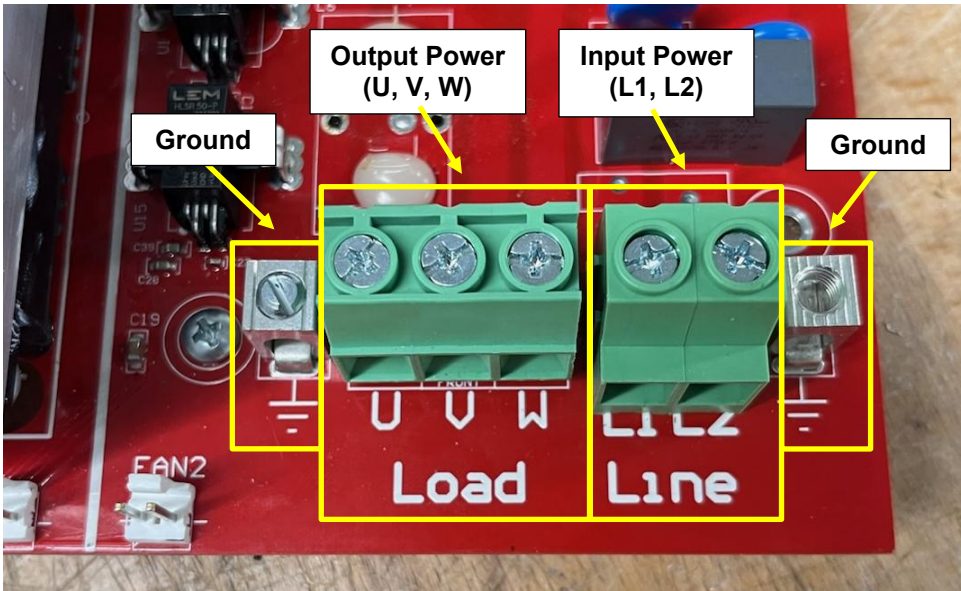

Figure 6 – Alpha Drive Power Terminal Location

*Installations must comply with all NEC and local electrical code requirements. The circuit breaker and fuse sizes listed in **Table 4** represent both the maximum allowable sizes and recommended sizes. According to the NEC, circuit breakers must be rated **at least 25% higher than the input current rating** to accommodate inrush currents and transient conditions safely.*

Table 4 – Input Circuit Breaker and Fuse Ratings (Inverse Time Circuit Breaker)

Model	Input/Output		Torque (lb-in)	Maximum Circuit Breaker / Fuse Rating Class J	Recommended Circuit Breaker
	Wire Size Range				
	Min	Max			
AD002R	26 AWG	6 AWG	10.5 lb-in	50 A, 600 V	25 A
AD003R	26 AWG	6 AWG	10.5 lb-in	70 A, 600 V	40 A
AD005R	26 AWG	6 AWG	10.5 lb-in	100 A, 600 V	60 A
AD007R	26 AWG	6 AWG	10.5 lb-in	175 A, 600 V	100 A
AD402R	26 AWG	6 AWG	10.5 lb-in	25 A, 600 V	15 A
AD403R	26 AWG	6 AWG	10.5 lb-in	30 A, 600 V	20 A
AD405R	26 AWG	6 AWG	10.5 lb-in	50 A, 600 V	50 A
AD407R	26 AWG	6 AWG	10.5 lb-in	70 A, 600 V	40 A
AD410R	26 AWG	6 AWG	10.5 lb-in	100 A, 600 V	60 A

4.2 Installing Power Cables

⚠ CAUTION: Continuous metal conduit should be used on all power cables, both line and load side, to reduce conducted and emitted radiation of electromagnetic interference (EMI). The conduit must be securely grounded to the enclosure of the drive and the motor case. If any conduit holes remain unused, they must be covered with a 3R hole plug to maintain the NEMA 3R rating.

Mitigating Electromagnetic Interference (EMI)

- Devices that utilize power switching electronics, such as VFDs, generate high-frequency emissions commonly referred to as electromagnetic interference (EMI). These emissions can be conducted along power cables or radiated through the air. The resulting noise may interfere with radio signals or sensitive electronic equipment located near the installation. To help reduce EMI, it is recommended to use shielded cables and rigid metal conduit on the output lines connecting the drive to the motor.
- Alpha Drives are equipped with an EMI Filter and RFI Choke.
- When it is not practical to use continuous metal conduit, special shielded cables can be used. The shielded cable should be constructed with symmetrical conductors and a copper or aluminum shield covered with an insulating jacket. A good shield results in lower EMI and lower motor bearing currents.

Routing Power Cables

- Power cables should enter the drive enclosure exclusively through the bottom, directly beneath the power terminals, using the conduit openings provided.
- It is important to avoid installing line-side power cables in the same conduit or cable tray as load-side power cables to prevent electrical interference and ensure safety. Additionally, control cables should not be routed through the same conduit or cable tray as power cables.
- Any unused conduit openings must be covered with conduit hole plugs to prevent dust, debris, or accidental contact, thereby maintaining a safe and organized installation.

Routing Control Wires

A separate, smaller conduit opening is supplied for control cables. If the control cables must intersect the power cables, make sure they cross at right angles.

⚠ CAUTION: Avoid routing control cables near power cables to avoid coupling EMI onto control cables.

⚠ CAUTION Use an appropriately sized hole punch. Do not use a hole saw to create openings! Metal filings may damage the drive and void the warranty.

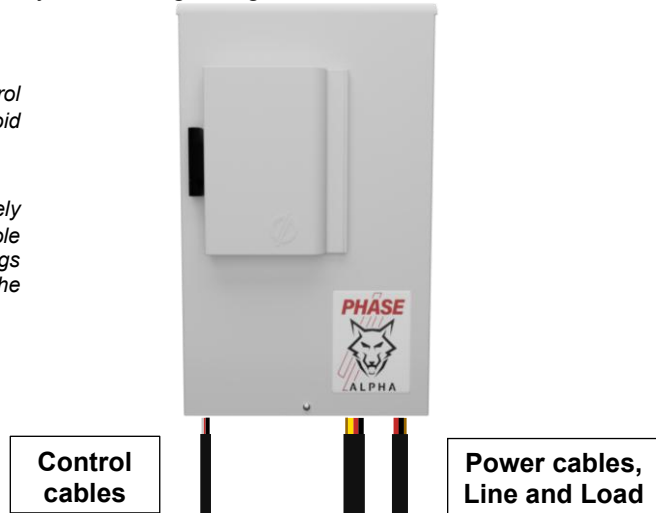

Figure 7 – Routing Power and Control Cables

4.3 Generator Power

Variable Frequency Drives can be powered by a generator, but it is recommended that the generator be sized 150% larger than the VFD rating. The table below illustrates how to calculate generator size in kilowatts.

Table 5 – Generator Sizing Recommendations

<i>How to Calculate Generator Size (in kW)</i>
<p><i>Generator size (kW) = Maximum VFD Amp Rating x 1.5 x 1.732 x Motor Nameplate Voltage/1000</i></p> <p>Maximum VFD Amps = nameplate current of the VFD</p> <p>1.5 (or 150%) = general rule to accommodate losses and differences in generators</p> <p>1.732 = square root of 3 (for 3 phase generators, delete for 1 phase generators)</p> <p>Motor Nameplate Voltage = voltage rating of the motor, not the power source)</p> <p>1000 = Divide by 1000 to convert watts to kilowatts</p>

If a generator will be used for backup power, a delay timer must be used to allow the VFD to completely shut down before transferring to a new power source. This delay should be a minimum of 30 seconds.

Important: Do not operate this drive with a Ground Fault Circuit Interrupter (GFCI). If using an externally regulated generator, ensure that the voltage, frequency (hertz), and idle speed are suitable and stable to properly supply power to the drive.

4.4 Output Filters

- Without the use of filters, long cable runs can allow reflected harmonic waves to generate dangerous voltage spikes. These spikes may exceed the insulation ratings of motor cables and windings, leading to insulation degradation over time and eventual motor failure.
- An output filter reduces the harmonic content in the PWM output voltage, producing a smoother waveform that minimizes mechanical vibrations within the motor. Additionally, filters help decrease common-mode currents flowing through the motor windings, which can discharge through bearings, causing pitting and increasing the risk of premature motor failure. Incorporating an output filter not only protects the motor but also enhances its longevity and operational reliability.

Recommended: Since there are no regulations governing the use of output filters, it is essential to follow the motor manufacturer's guidelines regarding acceptable cable lengths when operating VFDs. Adhering to these recommendations helps ensure optimal performance, reliability, and safety regardless of industry standards.

Typical Output Filter Application: >800' @ 230V dV/dt filter; >50' @ 460V Sine filter
https://www.phasetechnologies.com/downloads/MP_Manual_v1_0_cc1a8b6032.pdf

4.5 Control Terminals

- The drives are equipped with Control Terminals that allow several control functions, including remote ON/OFF control, digital output signals, remote notification, and operation of constant pressure water systems.
- The correct **1.3.1 SYSTEM CONFIG** must be selected for proper operation of the different types of control systems See **Table 21** for details.

⚠ WARNING: Do not connect Control Terminals to external circuits with voltage greater than that specified for each Control Terminal in

Table 6. De-energize the unit by disconnecting all incoming sources of power, then wait for the time specified on the drive warning label, before servicing the equipment.

⚠ CAUTION: The AUX1 – AUX3 terminals are galvanically isolated, with approximately 5 V potential between them. DO NOT apply voltage to the terminals. Use dry contacts only.

- Customer terminals are located on the Control Board of each drive. **Figure 8** shows where the Control Terminals are located on the Control Board for each system. See **Table 6** for information on the function of control terminals.

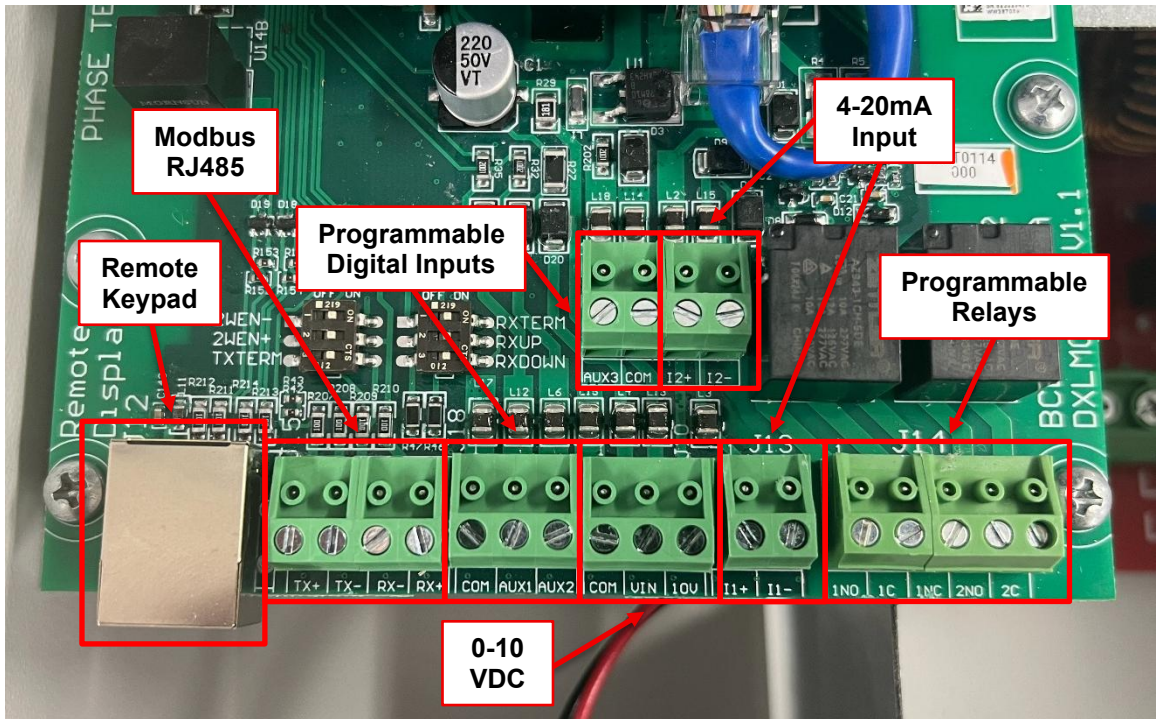

Figure 8 – Control Terminals

Table 6 – Control Terminal Ratings and Descriptions

Terminal Designator	Description	Rating	Comments
I 1+	4-20 mA Positive	4-20 mA	Analog transducer connection for analog constant pressure or proportional motor speed control from a current source. See Figure 9 for a connection diagram to control terminals.
I 1-	4-20 mA Negative		
I 2+	4-20 mA Positive		
I 2-	4-20 mA Negative		
10 V	0-10 VDC Output	0-10 VDC	10 VDC supply to provide power to a potentiometer. See Figure 10 for a connection diagram to control terminals.
VIN	10 VDC		Analog input for motor speed control for 0-10 VDC. Speed is relative to scale of signal from 0 Hz to 1.1.2 MAXIMUM FREQUENCY (default 60 Hz). Connect the wiper terminal of a potentiometer to this terminal. See Figure 10 for a connection diagram.
COM	Common		Common for 0-10 VDC.
AUX1	Auxiliary 1	< 5 Volts galvanically isolated	Programmable digital input. Commonly used for RUN/STOP command. See Table 21 for details.
AUX2	Auxiliary 2		
AUX3	Auxiliary 3		
COM	Common	-	Common for all terminals except programmable relays.

1NO	Normally Open Relay	30 VDC or 277VAC, 10A	Relay controlled by the conditions set in Parameter 1.3.4 PROGRAM RELAY 1 . See Table 21 for programming instructions.
1NC	Normally Closed Relay		
1C	Common		Common terminal for 1NC and 1NO terminals. CAUTION: Do not use as common for other terminals.
2NO	Normally Open Relay		Relay controlled by the conditions set in Parameter 1.3.5 PROGRAM RELAY 2 . See Table 21 for programming instructions.
2C	Common	Common terminal for 2NC and 2NO terminals. CAUTION: Do not use as common for other terminals.	
TX+	Transmitting Positive	< 5 Volts galvanically isolated	Connections for Modbus RTU and BACnet MS/TP.
TX-	Transmitting Negative		
RX-	Receiving Negative		For two wire communication, locate the “S3” DIP switch array and turn on 2WEN+ and 2WEN-. This will short RX+ and TX+ as well as RX- and TX-. Wire communication signals to terminals RX+ and RX-.
RX+	Receiving Positive		For four wire communication, wire signal wires to all four terminals.

4-20 mA Analog Input

Motor speed can be controlled with 4-20 mA analog input through control terminals **I1** and **I2**. A 4-20mA pressure transducer is also commonly used for constant pressure control through these terminals.

4-20 mA Transducer Connection:

1. Using the keypad, set the value of parameter **1.3.1 SYSTEM CONFIG** to 2, 3, 4 or 6 depending on the desired mode of operation. See **Figure 9a**, **Table 21**, and **Section 7.5** for details.
2. Connect the positive lead of the transducer to terminal I1+ or I2+
3. Connect the negative lead of the transducer to terminal I1- or I2-
4. AUX terminals must be closed to run.

4-20 mA Transducer with External Voltage Source Connection:

1. Using the keypad, set the value of parameter **1.3.1 SYSTEM CONFIG** to 2, 3, 4 or 6 depending on the desired mode of operation. See **Figure 9b**, **Table 21**, and **Section 7.5** for details.
2. Connect the positive lead of the transducer to terminal I1- or I2-
3. Connect the negative lead of the transducer to COM
4. AUX terminals must be closed to run.

⚠ CAUTION: A 4-20 mA transducer with the parameter **1.3.1 SYSTEM CONFIG** set at 6 results in linear speed control of the motor based on the analog signal from the transducer. This setting will not provide control of a constant pressure water system. For constant pressure control with 4-20 mA transducer, refer to **Section 8.1** for more information.

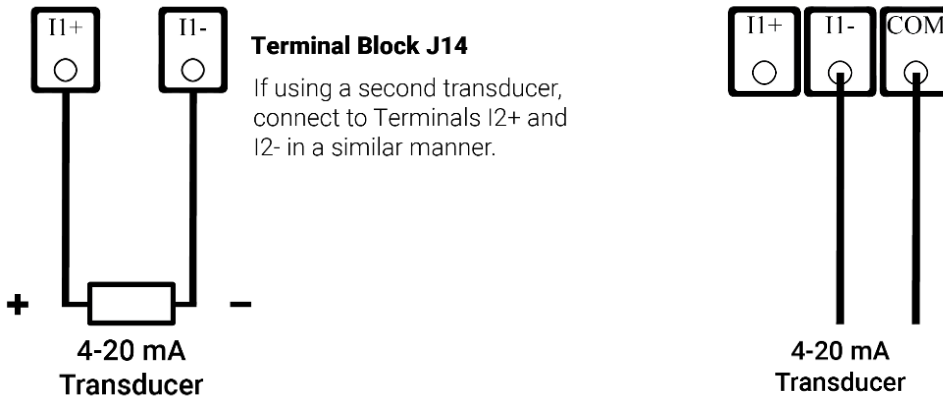

a. 4-20 mA Transducer Connection

b. 4-20 mA Transducer with External Voltage Source

Figure 9 – Control Terminal Connection Diagram for 4-20 mA Control

0-10 VDC Analog Input

Motor speed can be controlled with a 0-10 VDC signal through control terminals **VO**, **VIN** and **COM**. When using a speed potentiometer (variable resistor) the drive provides a DC source voltage. Speed control can also be accomplished with an external DC voltage signal.

Potentiometer connection:

1. Using the keypad, set the value of parameter **1.3.1 SYSTEM CONFIG** to 7. Refer to **Figure 10a** for terminal connection details.
2. Connect the negative lead of the potentiometer to COM
3. Connect the wiper terminal of the potentiometer to VIN
4. Connect the positive lead of the potentiometer to 10V
5. AUX terminals must be closed to run

External DC voltage signal:

1. Using the keypad, set the value of parameter **1.3.1 SYSTEM CONFIG** to 5. Refer to **Figure 10b** for terminal connection details.
2. Connect negative lead to COM
3. Connect positive lead to VIN

⚠ CAUTION: The resistance value of the potentiometer must be from 5,000 ohms to 20,000 ohms. Resistance below 5,000 ohms will produce a high current and may damage components in the circuit.

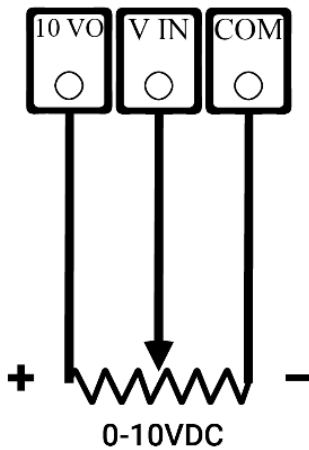

a. Potentiometer Connection Diagram

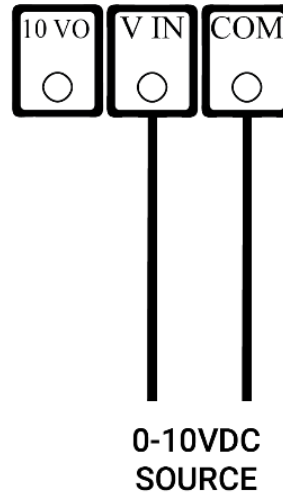

b. External DC Voltage Connection Diagram

Figure 10 – Control Terminal Connection Diagram for 0-10 VDC Control

PID Control with Potentiometer and HOA Switch

- The drives can be configured with a HOA switch that allows the user to either turn the motor off, control motor speed with a potentiometer, or operate in constant pressure mode. Access to the keypad is not required to operate in this mode.
- Using the keypad, set parameter **1.3.1 SYSTEM CONFIG** to 7. See **Figure 11** and **Table 21** for details.
 1. Connect the potentiometer and 4-20 mA transducer.
 2. Connect a double pole, triple throw HOA switch to AUX1 and AUX3.
 3. Using the keypad, set the drive to operate in AUTO mode by pressing the MANUAL button until the screen shows “AUTO”.
 4. AUX2 must be closed to run.
- The mechanical HOA switch provides the user with three operational options: OFF, manual speed control, and automatic control. In the H (Hand/Manual) position, the motor speed is regulated using the potentiometer, allowing for manual adjustments. When switched to the O (Off) position, the motor will stop entirely. Selecting the A (Auto) position enables the motor to be controlled automatically based on constant pressure parameters, allowing for pressure-based operation.

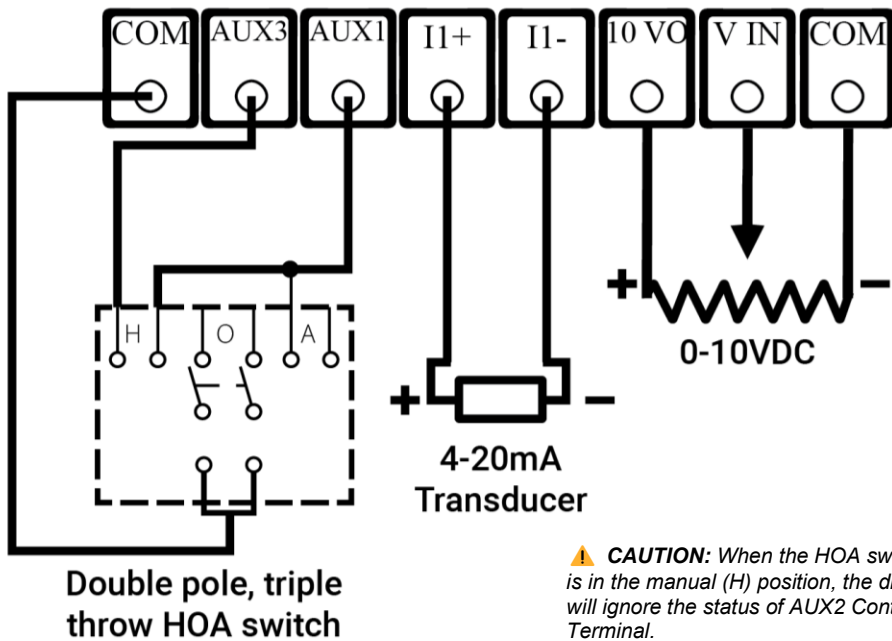

Figure 11 – Connections for PID Control with Potentiometer and HOA Switch

5 Keypad & Display

Before operating the motor load, several basic settings and procedures must be completed. If desired, extensive features for motor protection and special operating conditions are available through the keypad. Before initial power up, it is advisable to become familiar with setting motor overload protection and setting **1.3.1 SYSTEM CONFIG** with basic operation of the keypad and display.

5.1 Using the Keypad and Display

- Phase Technologies drives are capable of many advanced, easy-to-use features that allow the user to protect the motor load from damage, monitor load conditions, log motor run time, troubleshoot the system, and more. All drives are equipped with an onboard display and keypad, installed on the interface control board.

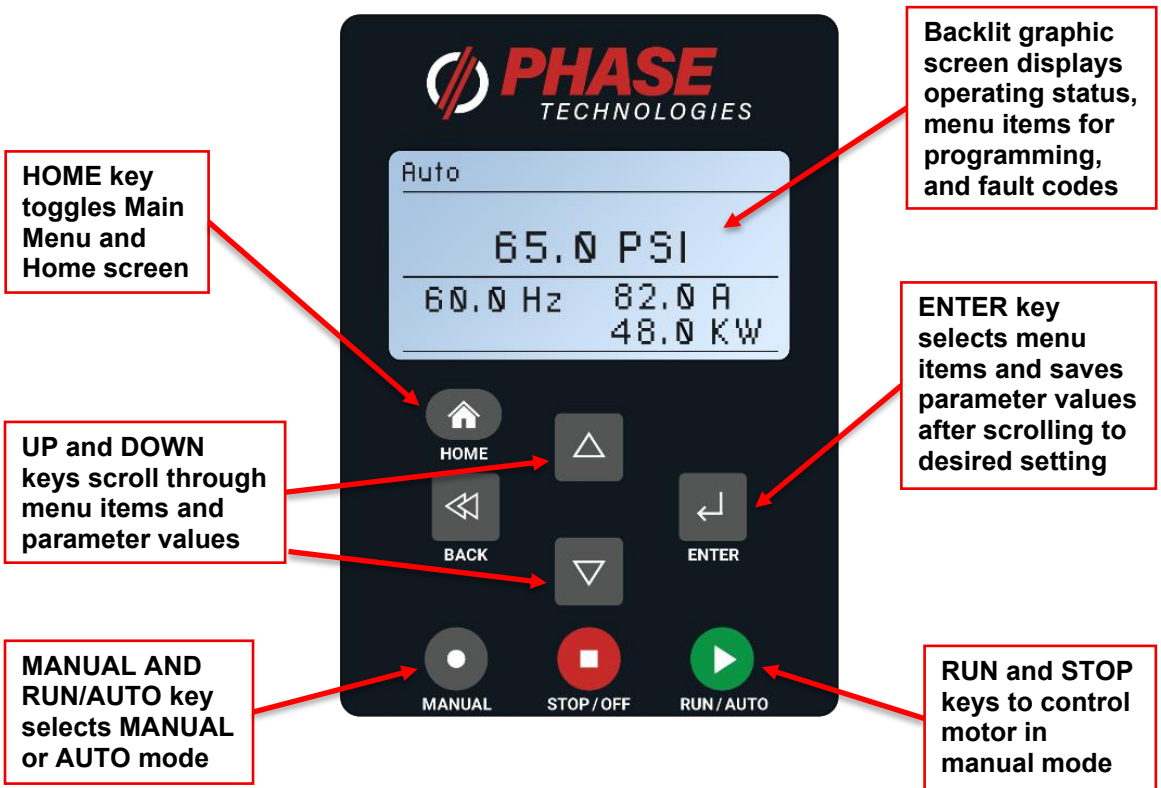

Figure 12 – Keypad and Graphic Display

Remote Display

- A remote display kit can be purchased to operate Alpha Drives, when installed in a panel or for a more comfortable programming experience. To use a remote display, turn the drive off and connect an RJ45 cable from the drive's control board terminal, "J12 REMOTE DISPLAY," located on the bottom left corner of the control board, to the "BLK" terminal on the remote display. When the drive is powered back on, it will recognize the remote display and will automatically connect to it.

Display Modes

- After two minutes of keypad inactivity, the display will revert to the default display mode.
- Information on the display will vary based on the operating mode of the drive. When operating in AUTO mode with the factory default **1.3.1 SYSTEM CONFIG** set to 0, the display will indicate output kilowatts (kW), output amps (A), and output frequency (Hz), or will show the status of the AUX1 and AUX2 inputs, if they are not both providing RUN commands.

Password Protecting the Keypad

- The keypad can be set up with a password to prevent unauthorized changes in adjustable parameters. The parameter **1.3.20 PASSWORD SETUP (Table 21)** is used to protect the keypad. When this parameter is set to 0 the keypad is not protected. Contact customer service at 605-343-7934 if you lose or forget the password.

Keypad Display Messages

- Several messages will appear on the display when the unit is initially energized. When the unit has completed its start-up routine, the default display indicating the status of the OFF, AUTO, MAN mode will appear. Start-up display messages are detailed in **Table 7** below.

Table 7 – Display of Operating Modes

MODE	DESCRIPTION
AUTO	<p>The factory default operating mode is OFF. The adjustable parameter, 1.2.1 ENABLE RESTARTS, must be set to YES to allow automatic re-starts. See Table 18 for details.</p> <p>⚠ CAUTION: <i>In AUTO mode, the motor load will automatically run if both AUX1 and AUX2 remote switches are open. Close AUX1 or AUX2 to stop the motor or push STOP/OFF key.</i></p> <p>⚠ CAUTION: <i>By default, AUX1 and AUX2 are programmed to run when open. See 1.3.8 AUX1 SELECT and 1.3.19 AUX2 SELECT to change this setting.</i></p>
MANUAL	<p>Activate MANUAL mode by pushing the MANUAL key until MANUAL appears on top left of the display. In MANUAL mode the motor load is controlled by using the RUN and STOP keys, which will override all external control signals.</p> <p>Manual control of the drive through the keypad can be disabled through the parameter 1.3.3 DISABLE MANUAL MODE. See Table 21, for details.</p> <p>⚠ CAUTION: <i>Operating the system in MANUAL mode on the keypad overrides signals from all external controls, including pressures switches. Operating the system in this mode may lead to dangerous operating conditions such as extreme pressure in closed plumbing systems.</i></p>
OFF	<p>The factory default operating mode is OFF. The adjustable parameter, 1.2.1 ENABLE RESTARTS, must be set to YES to allow automatic re-starts. To exit AUTO mode, press the STOP/OFF key. If the motor is running, it will stop. To restart the motor, revert to either AUTO mode or MANUAL mode. Certain faults can also be cleared by pressing and holding both the UP and DOWN arrow keys for one second.</p>

6 Main Menu Parameters

- The HOME key toggles between the Home screen (operating status screen) and the Main Menu items. Use the UP and DOWN arrows to scroll through the Main Menu items. Press ENTER to view or edit a Main Menu item. **Table 8** contains a brief description of Main Menu items, followed by in-depth instructions on the use and function of each Main Menu item.

Table 8 – Main Menu Parameters

DISPLAY MESSAGE	DESCRIPTION
1 CHANGE PARAMETER VALUES	Allows the user to set values for functions such as motor overload settings, under current, time to restart after a fault, etc.
3 READ MEASURED VALUES (RMV)	Displays measured values such as output current, input voltage, load power factor, etc.
4 READ TIMERS	Records motor run time and drive on time.
5 RESTART LOG	A fault log that tracks and records the number of times a specific fault has occurred. This counter can be reset to zero via the CLEAR MEMORY menu.
6 FAULT LOG	Records the number of times a particular fault has occurred, along with the date and time of the 20 most recent fault events. The FAULT LOG cannot be reset by the user.
7 CLEAR MEMORY	This function clears the Restart Log and associated timers. All fault counters within the Restart Log will be reset to zero. If automatic restarts have been enabled through the Auto Restart Parameters (see Table 20), the counters for those faults will also be reset.
9 SETUP WIZARD	This feature enables quick setup of common control schemes, including Constant Pressure Control, Flow Control, Tank Level Control, Pump Down Control, Suction Pump Control, and HVAC Control. These setup wizards provide adequate control for most systems. For further fine-tuning, refer to the list of adjustable parameters in Section 6.14.
11 ALARMS	A resettable log that records the number of alarm occurrences. It also allows programming of various operating conditions to trigger either a Fault or an Alarm.
12 FILE SYSTEM	Opens the menu for importing and exporting settings or reprogramming firmware.

6.1 Change Parameter Values

- The Main Menu item, **1 CHANGE PARAMETER VALUES**, leads to several sub-menus that contain adjustable operating parameters. These parameters provide basic functions such as motor overload protection and advanced features that allow customized operation of the drive to fit the specific application.

Section 6.15 contains a complete list of the parameters along with a description of their function and instructions on setting them.

6.2 Read Measured Values

- The display can provide a variety of measured values related to the performance of the drive and its load such as currents, horsepower, and power factor. To read measured values:
 - Press the HOME key to access Main Menu items, and then scroll with arrow keys until **3 READ MEASURED VALUES** appears on the display.
 - Press ENTER to access this menu item.
 - Use the UP and DOWN arrow keys to scroll through the various values that you wish to read.

Table 9 – Read Measured Values

DISPLAY MESSAGE	DESCRIPTION OF MEASURED VALUE
3.1 Iu Iv Iw	Output currents, measured in Amps (A)
3.2 OUTPUT HP	Output measured in horsepower (HP)
3.3 OUTPUT kW	Output measured in kilowatts (kW)
3.4 OUTPUT kVA	Output measured in kilovolt amperes (kVA)
3.5 OUTPUT PF	Power factor of the motor load
3.6 FREQUENCY	Output frequency in Hertz (Hz)
3.11 BUS CAP VOLTAGE	Voltage of the DC bus, measured in Volts DC (VDC)
3.12 INPUT VOLTAGE	Input voltage, measured in Volts AC (VAC)
3.18 MODEL NUMBER	Indicates model number of the product and the firmware version of the Interface and Driver digital signal processors (DSP).
3.19 AUX1 AUX2	ON/OFF status of the remote switch circuits AUX1 and AUX2
3.20 AUX3 AUX4	ON/OFF status of the remote switch circuits AUX3 and AUX4
3.21 10VDC INPUT	Measures the 0-10 VDC analog control voltage between Control Terminals for 0-10 VDC input.
3.22 4-20 mA Input, I1, I2	Measures 4-20 mA analog control current on I1 and I2Control Terminals for analog current input.

DISPLAY MESSAGE	DESCRIPTION OF MEASURED VALUE
3.23 IGBT CASE TEMP	Insulated-gate bipolar transistor (IGBT) case temperature in degrees Celsius.
3.24 STARTUP DELAY	Displays a timer that counts down the time left to start when the drive is in a time delay due to a fault condition.
3.25 REAL-TIME CLOCK	Date/Time
3.26 MOTOR RPM	Displays the current RPM of the fan load. Parameter 1.1.28 MOTOR RPM must be programmed for this to display a reading.
3.27 RUN TIMER	Time until next restart if drive is waiting for a timer to expire.
3.28 CONNECTION STRENGTH	DSP communication strength. If below, 100%, check Control Board connections and/or improve grounding. Only visible when 1.3.29 TROUBLESHOOTING is set to "2".
3.29 INT BOOT FIRMWARE CRC	The boot loader version internal to the Interface DSP.
3.30 DRV BOOT FIRMWARE CRC	The boot loader version internal to the Driver DSP.
3.31 INTERNAL TEMP	Internal Temperature of the VFD measure by the DSP
3.32 DIP STATES	Shows the state of each dip switch

6.3 Read Timers

- The timer function records motor run time in hours, and the time the drive has been energized. There are two timers for each function, one can be reset, and one permanent. To view the timers:
 - Press MENU to scroll through menu items until **4 READ TIMERS** appears on the display.
 - Press ENTER to enter this menu item.
 - Use the up and down arrows to scroll through the clock functions.

Table 10 – Read Timers

TIMER	DESCRIPTION
4.1 Motor Run Time	Logs motor run time in Days/Hours/Minutes. Can be reset
4.2 Drive On Time	Logs Drive "On" time Days/Hours/Minutes. Can be reset
4.3 All Motor Hours	Logs total motor run time. Not resettable.
4.4 All Drive Hours	Logs total time the drive is energized. Not resettable.
4.5 Cycle Counters (Updated Weekly)	Logs the number of times the load has started in total, in the last year, and in the last month. Counts update once per week.
4.6 Cycle Counters (Updated Daily)	Logs the number of times the load has started in the last week, the previous day, and the current day. Counts update once per day.

Programming Tip

To reset the timers, navigate to the Main Menu item, **7 CLEAR MEMORY**, use arrow keys to select **RESET TIMERS**, and then press **ENTER**

6.4 Restart Log

- The Restart Log records the number of times each fault has occurred. The faults counters in the Restart Log are resettable and are tied to faults that allow programmable automatic restarts. These automatic restarts are programmed through **1.2 AUTO RESTART PARAMETERS**, which is a sub-menu of the Main Menu item **1 CHANGE PARAMETER VALUES**.
- For instance, in a water well pump application, it might be useful to protect the pump from dry well condition by setting the **1.1.10 UNDER CURRENT** parameter (found in the **1.1 OPERATING PARAMETERS** menu) so that the drive shuts down and registers a **1.1.10 UNDER CURRENT** fault in the Restart Log.
- The drive can also be programmed to automatically restart after a delay to allow the well to recover. Both the delay time and number of restarts can be programmed in **1.2 AUTO RESTART PARAMETERS**. The Restart Log allows the user to monitor the type and number of faults that have occurred. If the number of **1.1.10 UNDER CURRENT** faults exceeds the number of automatic restarts allowed, the drive will remain OFF until power is cycled off and back on.
- Output current (from read measured values) on each output terminal must remain below the dry well current programmed for the time set in Restart Delay 2 (auto restart parameters, default 15s) for the drive to fault.

➤ **To view the Restart Log:**

1. Press the HOME key, then use the UP and DOWN arrows to scroll through menu items until **5 RESTART LOG** appears on the display.
2. Press ENTER to access this menu item.
3. Use the UP and DOWN arrows to scroll through the faults.
4. The fault will appear on the first row of the display, followed by the number of times that fault has occurred.

➤ To clear the Restart Log and reset all Auto Restart fault counters:

1. Press the HOME key, then use the UP and DOWN arrows to scroll through the Main Menu items until **7 CLEAR MEMORY** appears on the display.
2. Press ENTER.
3. Use the UP and DOWN arrows to find **7.1 CLEAR RESTART LOG**.
4. Press ENTER to clear the Restart Log and reset all Auto Restart fault counters.

 **CAUTION:** Clearing the Restart Log through the **7 CLEAR MEMORY** menu will clear ALL faults in the Restart Log and all fault counters in the drive will be reset to zero.

- When the drive faults and is configured for automatic restart after a programmed delay, the display will count down the remaining time until restart. To manually interrupt this countdown and initiate the motor startup, press and hold both the UP and DOWN arrow buttons simultaneously for one second.

- If the drive has faulted and automatic restart is not enabled, the display will show the fault type on the top line, with the second line prompting, **RESTART? ENTER**. Press the ENTER button to acknowledge the fault, clear the message, and attempt to restart the load.

6.5 Fault Log

- The Fault Log is a permanent record of drive faults. The number of faults cannot be reset by the user. Faults will be stamped with the time and date the fault occurred, up to a total of 20 times for each fault. After the 20th fault, the oldest time-stamped fault will be replaced with the most recent.
- The Fault Log is a Main Menu item. Press the HOME key, then use the arrow keys to scroll until **6 FAULT LOG** appears. Press ENTER to view the list of faults, using the arrow keys to scroll through the list.

Programming Tip

A maximum of 20 time and date stamps can be applied to any given fault. After the 20th fault, the oldest fault time stamp will be erased and replaced by the most recent. The drive will continue to count faults up to a maximum of 9,999 for each individual fault.

6.6 Clear Memory

- The **7 CLEAR MEMORY** function in the Main Menu allows you to reset the timers that record motor run time and drive on time, and to reset the Restart Log which counts the number of each fault.
 1. Press HOME, then use the arrow keys to scroll until **7 CLEAR MEMORY** appears on the display.
 2. Press ENTER to enter this menu item.
 3. Use the UP and DOWN arrows to find either **7.1 CLEAR RESTART LOG** or **7.2 RESET TIMERS**.
 4. Press ENTER to reset the selected function.

6.7 Setup Wizards

- The Setup Wizard selection will be shown upon the first initialization of the VFD and can be accessed through the keypad at any time by scrolling through the Main Menu Items to the **9 SETUP WIZARD** menu.
- Setup Wizards allows users to quickly setup commonly used control schemes. See the following tables for Setup Wizard walkthrough:

9.1 Constant Pressure Control	(Table 11)
9.2 Flow Control	(Table 12)
9.3 Tank Level Control	(
Table 13)	
9.4 Pump Down Setup	(Table 14)
9.5 Suction Pump Setup	(
Table 15)	
9.6 HVAC Setup	(Table 16)
9.8 Pump Down OL Setup	(Table 17)

The wizards will guide users through a list of commonly used parameters for the selected control method.

Using these wizards will allow adequate control of most systems, but if additional fine-tuning is needed, see lists of adjustable parameters in **Section Error! Reference source not found. 6.15.**

Table 11 – 9.1 Constant Pressure Control Wizard

PROMPT	DESCRIPTION
Run Constant Pressure Wizard?	Press the “Enter” key to go through the wizard. Press “Home” key to return to Home screen.
Motor Phase	Select whether you plan to run a single-phase or three-phase motor.
Input Voltage	Select the voltage of the input power. 120V or 240 V
Motor Type	For single-phase motors only. Select 2-wire or 3-wire.
Motor Manufacturer	Select from a list of possible motor manufacturers to help tune the motor starting scheme. If your manufacturer is not available, select “Other”.
Max Analog Sensor Range	This is the maximum value of the psi sensor being used. Phase Technologies sensors have a maximum value of 150 psi.
Analog Setpoint 1	The pressure, in psi, that the drive will attempt to maintain.
Submersible Pump	The frequency will ramp from zero to the value set by parameter 1.1.1 MIN FREQUENCY (default: 30 Hz) within one second to protect the thrust bearing in submersible motors. <i>Please consult your motor manufacturer for the recommended thrust bearing protection frequency.</i>
Disable Manual Mode	Disables manual operation of the drive through the keypad. Allows the drive to disregard any controls and operates at max frequency when engaged.
Overcurrent Limit	Setting for motor overload protection, Trip Class 10 curve.

Table 12 – 9.2 Flow Control Wizard

PROMPT	DESCRIPTION
Run Flow Control Wizard?	Press the “Enter” key to go through the wizard. Press “Home” key to return to Home screen.
Motor Phase	Select whether you plan to run a single-phase or three-phase motor.
Input Voltage	Select the voltage of the input power. 120V or 240 V
Motor Type	For single-phase motors only. Select 2-wire or 3-wire.
Motor Manufacturer	Select from a list of possible motor manufacturers to help tune the motor starting scheme. If your manufacturer is not available, select “Other”.
Analog Setpoint 1	The flow, in Gallons Per Minute (GPM), that the drive will attempt to maintain.
Force Sleep Threshold	This value is <u>added</u> to the value 1.4.1 ANALOG SETPOINT 1 . The combined flow is the value the drive will stop the motor load at and enter sleep mode.
Wake Up Threshold	This value is <u>subtracted</u> from 1.4.1 ANALOG SETPOINT 1 and is the flow when the VFD will start the motor load again.
Sleep Frequency	In Hz. This parameter value is <u>added</u> to the frequency set by the parameter 1.1.1 MINIMUM FREQUENCY . The combined value is the frequency at which drive will enter sleep mode when GPM is controlled at the set point.
Submersible Pump	The frequency will ramp from zero to the value set by parameter 1.1.1 MIN FREQUENCY (default: 30 Hz) within one second to protect the thrust bearing in submersible motors. <i>Please consult your motor manufacturer for the recommended thrust bearing protection frequency.</i>
Disable Manual Mode	Disables manual operation of the drive through the keypad. Allows the drive to disregard any controls and operates at max frequency when engaged.
Overcurrent Limit	Setting for motor overload protection, Trip Class 10 curve.

Table 13 – 9.3 Tank Level Control Wizard

PROMPT	DESCRIPTION
Run Tank Level Control Wizard?	Press the “Enter” key to go through the wizard. Press “Home” key to return to Home screen.
Motor Phase	Select whether you plan to run a single-phase or three-phase motor.
Input Voltage	Select the voltage of the input power. 120V or 240 V
Motor Type	For single-phase motors only. Select 2-wire or 3-wire.
Motor Manufacturer	Select from a list of possible motor manufacturers to help tune the motor starting scheme. If your manufacturer is not available, select “Other”.
Analog Setpoint 1	The height, in feet, that the drive will attempt to maintain.
Force Sleep Threshold	This value is <u>added</u> to the value 1.4.1 ANALOG SETPOINT 1 . The combined height is the value the drive will stop the motor load at and enter sleep mode.
Wake Up Threshold	This value is <u>subtracted</u> from 1.4.1 ANALOG SETPOINT 1 and is the height when the VFD will start the motor load again.
Sleep Frequency	In Hz. This parameter value is <u>added</u> to the frequency set by the parameter 1.1.1 MIN FREQUENCY . The combined value is the frequency at which drive will enter sleep mode when level is controlled at the set point.
Submersible Pump	The frequency will ramp from zero to the value set by parameter 1.1.1 MIN FREQUENCY (default: 30 Hz) within one second to protect the thrust bearing in submersible motors. <i>Please consult your motor manufacturer for the recommended thrust bearing protection frequency.</i>
Disable Manual Mode	Disables manual operation of the drive through the keypad. Allows the drive to disregard any controls and operates at max frequency when engaged.
Overcurrent Limit	Setting for motor overload protection, Trip Class 10 curve.

Table 14 – 9.4 Pump Down PID Setup Wizard

PROMPT	DESCRIPTION
Run Pump Down Setup Wizard?	Press the “Enter” key to go through the wizard. Press “Home” key to return to Home screen.
Motor Phase	Select whether you plan to run a single-phase or three-phase motor.
Input Voltage	Select the voltage of the input power. 120V or 240 V
Motor Type	For single-phase motors only. Select 2-wire or 3-wire.
Motor Manufacturer	Select from a list of possible motor manufacturers to help tune the motor starting scheme. If your manufacturer is not available, select “Other”.
Analog Setpoint 1	The height, in feet, that the drive will attempt to maintain.
Force Sleep Threshold	This value is <u>subtracted</u> from the value 1.4.1 ANALOG SETPOINT 1 . The resulting height is the value when the drive will stop the motor load at and enter sleep mode.
Wake Up Threshold	This value is <u>added</u> to 1.4.1 ANALOG SETPOINT 1 . The combined value is the height when the VFD will start the motor load again.
Sleep Frequency	In Hz. This parameter value is <u>added</u> to the frequency set by the parameter 1.1.1 MIN FREQUENCY . The combined value is the frequency at which drive will enter sleep mode when level is controlled at the set point.
Submersible Pump	The frequency will ramp from zero to the value set by parameter 1.1.1 MIN FREQUENCY (default: 30 Hz) within one second to protect the thrust bearing in submersible motors. <i>Please consult your motor manufacturer for the recommended thrust bearing protection frequency.</i>
Overcurrent Limit	Disables manual operation of the drive through the keypad.
Sleep Frequency	Setting for motor overload protection, Trip Class 10 curve.

Table 15 – 9.5 Suction Pump Setup Wizard

PROMPT	DESCRIPTION
Run Suction Pump Setup Wizard?	Press the “Enter” key to go through the wizard. Press “Home” key to return to Home screen.
Motor Phase	Select whether you plan to run a single-phase or three-phase motor.
Input Voltage	Select the voltage of the input power. 120V or 240 V
Motor Type	For single-phase motors only. Select 2-wire or 3-wire.
Motor Manufacturer	Select from a list of possible motor manufacturers to help tune the motor starting scheme. If your manufacturer is not available, select “Other”.
Analog Setpoint 1	In psi. Used only for transducers wired to 1_2. The pressure setting where any value lower will trigger a fault.
Low Pressure Fault Level	In psi. This is the inlet pressure that will signify a loss of suction pressure and trigger a fault.
Suction Pressure Time	In seconds. The time at which the pressure must remain below 1.4.40 Low Pressure Fault Level before triggering a fault.
Submersible Pump	The frequency will ramp from zero to the value set by parameter 1.1.1 MIN FREQUENCY (default: 30 Hz) within one second to protect the thrust bearing in submersible motors. <i>Please consult your motor manufacturer for the recommended thrust bearing protection frequency.</i>
Disable Manual Mode	Disables manual operation of the drive through the keypad.
Overcurrent Limit	Setting for motor overload protection, Trip Class 10 curve.

Table 16 – 9.6 Speed Reference Setup Wizard

PROMPT	DESCRIPTION
Run Speed Reference Setup Wizard?	Press the “Enter” key to go through the wizard. Press “Home” key to return to Home screen.
Motor Phase	Select whether you plan to run a single-phase or three-phase motor.
Input Voltage	Select the voltage of the input power. 120V or 240 V
Motor Type	For single-phase motors only. Select 2-wire or 3-wire.
Motor Manufacturer	Select from a list of possible motor manufacturers to help tune the motor starting scheme. If your manufacturer is not available, select “Other”.
Min Frequency	In Hz: The lowest frequency at which the drive will operate the load. If a submersible pump is selected, the drive will ramp from zero to the value set by parameter 1.1.1 MIN FREQUENCY within one second.
Max Frequency	In Hz. The maximum frequency that the drive will operate the load at.
Disable Manual Mode	Disables manual operation of the drive through the keypad.
Overcurrent Limit	Setting for motor overload protection, Trip Class 10 curve.

Table 17 – 9.8 Pump Down OL Setup Wizard

PROMPT	DESCRIPTION
Run Speed Reference Setup Wizard?	Press the “Enter” key to go through the wizard. Press “Home” key to return to Home screen.
Motor Phase	Select whether you plan to run a single-phase or three-phase motor.
Input Voltage	Select the voltage of the input power. 120V or 240 V
Motor Type	For single-phase motors only. Select 2-wire or 3-wire.
Motor Manufacturer	Select from a list of possible motor manufacturers to help tune the motor starting scheme. If your manufacturer is not available, select “Other”.

Max Analog Sensor Range	This value should be set to the maximum value of the 4-20 mA transducer being used for suction pressure control. i.e. if the transducer has a range of 0-150 psi, the parameter should be set to 150.
Pump Down OL On Level	The level where the pump will turn on and run at 1.1.1 MINIMUM FREQUENCY .
Pump Down OL Mid Freq Level	The level where the pump will run at mid frequency.
Pump Down OL Max Freq Level	The level where the pump will run at 1.1.2 MAX FREQUENCY .
Pump Down OL Off Level	The level where the pump will turn off.
Submersible Pump	The frequency will ramp from zero to the value set by parameter 1.1.1 MIN FREQUENCY (default: 30 Hz) within one second to protect the thrust bearing in submersible motors. <i>Please consult your motor manufacturer for the recommended thrust bearing protection frequency.</i>
Disable Manual Mode	Disables manual operation of the drive through the keypad.
Overcurrent Limit	Setting for motor overload protection, Trip Class 10 curve.

6.8 Changing Parameter Values

⚠ WARNING: When the drive is set to automatically restart after a fault, the output terminals can energize and the load can start without warning, exposing the user to risk of serious injury. Make certain the input is de-energized before approaching the equipment.

- The **1 CHANGE PARAMETER VALUES** function allows the user to set values for a variety of functions including motor overload settings, number of restarts after a fault, and more.
- **To access 1 CHANGE PARAMETER VALUES**
 1. Press the HOME key until **1 CHANGE PARAMETER VALUES** appears on the display.
 2. Press ENTER to access this menu item.
 3. Use the UP and DOWN arrows to scroll through the sub-menu to find the item desired, then press ENTER. See **Table 19** through **Table 25** for a list of parameters.
 4. Use the UP and DOWN arrow keys to scroll to the desired parameter, press ENTER, then use the UP and DOWN arrows to change the value.
 5. When the value you want appears on the display, press ENTER to set the value or BACK to cancel.

6.9 Restore Default Parameter Settings

⚠ CAUTION: The drive output must be stopped before resetting. Failure to do so may result in damage to the drive or equipment.

- To restore **ALL** adjustable parameters (except for **1.1.14 REVERSE ROTATION**, **1.3.20 PASSWORD SETUP**, **1.1.16 SWITCHING FREQUENCY**, and **1.3.19 ENABLE 1PH INPUT**) to their default value, press and hold the BACK and ENTER keys at once and hold for three seconds. If a password is configured, you will be prompted to enter the password first. You will then be prompted to press ENTER for yes or BACK for no.

6.10 Auto Restarts

- The drive can be programmed to automatically restart after certain faults. Using the **1.2 AUTO RESTART PARAMETERS (Table 20)**, you can set a time delay before the drive starts after a fault and select the number of automatic restarts allowed before the unit will remain OFF after a fault.

Example: You wish to allow 10 automatic restarts after a fault but want the drive to wait for one hour, to allow the well to recover, before restarting. When the drive is counting down the time to restart after a fault, the display will indicate the time until restart in seconds.

Programming Tip

To interrupt the countdown and allow a restart, push and hold both the UP and DOWN keys for one second. The load will start immediately.

- When the drive reaches the limit of faults set by the adjustable parameter, it will remain OFF and the display will indicate the type of fault on the top line. The second line will read **RESTART? ENTER**. Press ENTER to clear the fault and restart the load. The fault counters in the **5 Restart Log** will all be reset to zero. See **Section 6.4** for more information. Some faults do not allow auto restart. The display will read **NO AUTO RESTART**. See **Section 6.5, Fault Log**, for more information.

6.11 All Parameters List

- To aid in troubleshooting, a numbered parameter list containing all parameters is available for use. Some parameters are visible that are not always used. In this case, the word “Disabled” is shown, and programming functionality is disabled for that parameter.
 - **To access 1.7 ALL PARAMETERS:**
 1. Press the HOME key to access Main Menu items, and then scroll with arrow keys until **1 CHANGE PARAMETER VALUES** appears on the display.
 2. Press ENTER to access this menu item.
 3. Use the UP and DOWN arrow keys to scroll to **1.7 ALL PARAMETERS**.
 4. Press ENTER to access this menu item.

6.12 Changed Parameter List

- This is a list of all parameters that have been changed from their default values. This allows for quick and easy programming of previously changed parameter values. The total number of changed parameters and the index of changed parameters will be displayed at the top of the screen. If there are no changed parameters, then “No Changed Parameters” will be shown.
 - **To access 1.8 CHANGED PARAMETER VALUES:**
 1. Press the HOME key to access Main Menu items, and then scroll with arrow keys until **1 CHANGE PARAMETER VALUES** appears on the display.
 2. Press ENTER to access this menu item.
 3. Use the UP and DOWN arrow keys to scroll to **1.8 CHANGED PARAMTERS**.
 4. Press ENTER to access this menu item.

6.13 File System

- Drives are equipped with a USB terminal that can be used to Import and Export Parameters as well as install firmware upgrades or custom firmware. Firmware files will be .hex format and parameter data files will be saved as a .CSV file.

 **CAUTION:** *USB device must be inserted while drive is **powered off**. Failure to do so may result in injury or damage to the product. Power may be applied while USB device is inserted, but the system must be powered off before removing the USB from the terminal. Always turn power to the system off and wait for the discharge time specified on the front label to allow the DC bus to discharge before working in the enclosure.*

- With the drive powered off, locate the USB terminal on the control board. **Figure 13** below shows the USB terminal on a control board. Insert the USB device into the terminal, replace the enclosure cover, and apply power to the drive.

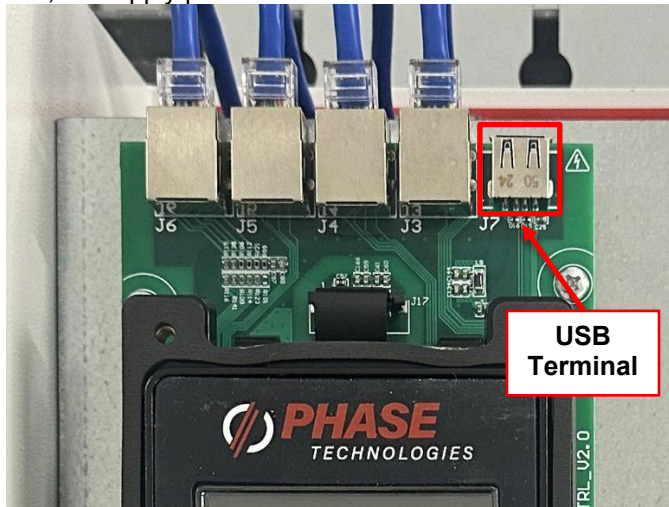

Figure 13 – USB Terminal on Drive Control Board

12.1 USB DRIVE EXPORT DATA

- **To access 12.1 USB Drive Export Data**
 1. From the HOME screen, press ENTER, then scroll down to **12 FILE SYSTEM** and press ENTER.
 2. Use the up and down arrows to select **12.1 USB DRIVE EXPORT DATA** parameter on the display and press ENTER.
 3. Parameter data will be exported to a .CSV file on the USB device. If the export was successful, the display will show **EXPORT SUCCESSFUL**. Power down your drive to remove the USB. If the screen shows **EXPORT FAILED**, cycle power and retry steps 1 – 3.
 4. The file can now be used to import parameters to another VFD. The file can also be opened on a personal computer to view and troubleshoot parameter settings.
- The file format of the parameter data will be a .CSV file, which can be opened by Microsoft Excel.
-
- Table 18 below shows the format of the exported parameter data.
- **8 Categories of Exported Information:**
 1. Drive model, software, firmware, and export time stamp

2. All Adjustable Parameters: To include what they are programmed to, their adjustment range, whether they are changed from default and what they have been changed to.
3. Measured Parameters: This will include measurements taken from **3 READ MEASURED VALUES** at the time of export. Ex: Current, Voltage, Temp, Frequency, Analog Signals
4. Changed Parameters Only: Includes only the parameters that have been changed
5. Interface Reprogram Count: Displays the number of updates via USB to the Interface Board and will display the current version number.
6. Drive Reprogram Count: Displays the number of updates via USB to the Driver Board and will display the current version number.
7. Fault Log: Displays stored faults and their associated timestamps
8. Alarm Log: Displays stored alarms and the number of associated alarms

Table 18 – Exported Data Example

Model Info: AD005R SW 1.0.1.0					
Drive Family: Alpha					
Firmware Family: Production					
Date/Time: 25/20/2064 33:83:24					
Boot Firmware: 01.00					
Boot CRC: 0xB63E5EFF					
All Parameters					
Name	Current	Default	Minimum	Maximum	Changed
Output Voltage	230	230	200	230	
Overcurrent Limit	30	30	3	32	
Dry Well Current	0	0	0	30	
Current Unbalance	80	80	1	100	
Min Frequency	33	30	5	120	Yes
Restart Delay	60	60	0	9999	

12.2 USB DRIVE IMPORT PARAMETER DATA

- The exported Parameter Data files can be used to apply the same parameters to other drives. This will exclude any parameters that are model-specific, such as **1.1.9 OVERCURRENT LIMIT**.
 - **To export parameter data:**
 1. From the HOME screen, press ENTER, then scroll down to **12 FILE SYSTEM** and press ENTER.
 2. Use the up and down arrows to select **12.2 IMPORT PARAMETER DATA** on the display and press ENTER.

3. Next, select whether you want to import Model-specific data, which includes **Overcurrent Limit, Under Current Limit, Switching Frequency, Motor Rated HP, and Motor Rated Current**.
4. Use the Up and Down arrows to select the file of parameters to be applied and press **ENTER**.
5. If the parameter import is successful, the display will show **IMPORT SUCCESSFUL**. If the screen displays **IMPORT UNSUCCESSFUL**, cycle power and retry steps 1 – 5.

12.5 REPROGRAM FIRMWARE

- If needed, the USB terminal can be used to reprogram the firmware of the VFD for software upgrades or custom features.
 - **To access reprogram firmware:**
 1. Turn power to the system OFF and insert the USB device into the USB port at the top of the INTF control board **Figure 12**.
 2. Reapply power to the drive.
 3. From the HOME screen, press ENTER, then scroll down to **12 FILE SYSTEM** and press **ENTER**.
 4. Use the up and down arrows to select **12.5 REPROGRAM FIRMWARE** on the display and press **ENTER**.
 5. Use the up and down arrows to select the “INTF” firmware file for reprogramming and press **ENTER**.
 6. If the file chosen contains the proper firmware for the VFD model, reprogramming will begin. Reprogramming firmware will take several minutes. If the LEDs, labeled TX and RX, on the INTF board are flashing, that means that the reprogramming process is underway.
 7. If the reprogram is successful, the display will show **SUCCESSFUL, PRESS ENTER or CYCLE POWER TO RESET**.
 8. If the display shows **UNSUCCESSFUL**, cycle power and retry steps 1 – 5.
 9. Press **ENTER** and the drive will reboot with the new software version.
 10. This will erase all programming to factory default and the drive will initialize with the setup wizard.

Programming Tip

1. *Export drive programming prior to firmware update via **12.1 USB DRIVE EXPORT DATA***
2. *Reprogram Firmware via **12.5 REPROGRAM FIRMWARE***
3. *Import drive programming back after firmware update via **12.2 USB DRIVE IMPORT PARAMETER DATA***
 - a. *Select “YES” when prompted for “Model Specific”*
4. *Always confirm that parameters were imported.*

6.14 Menu Structure Overview (Tree)

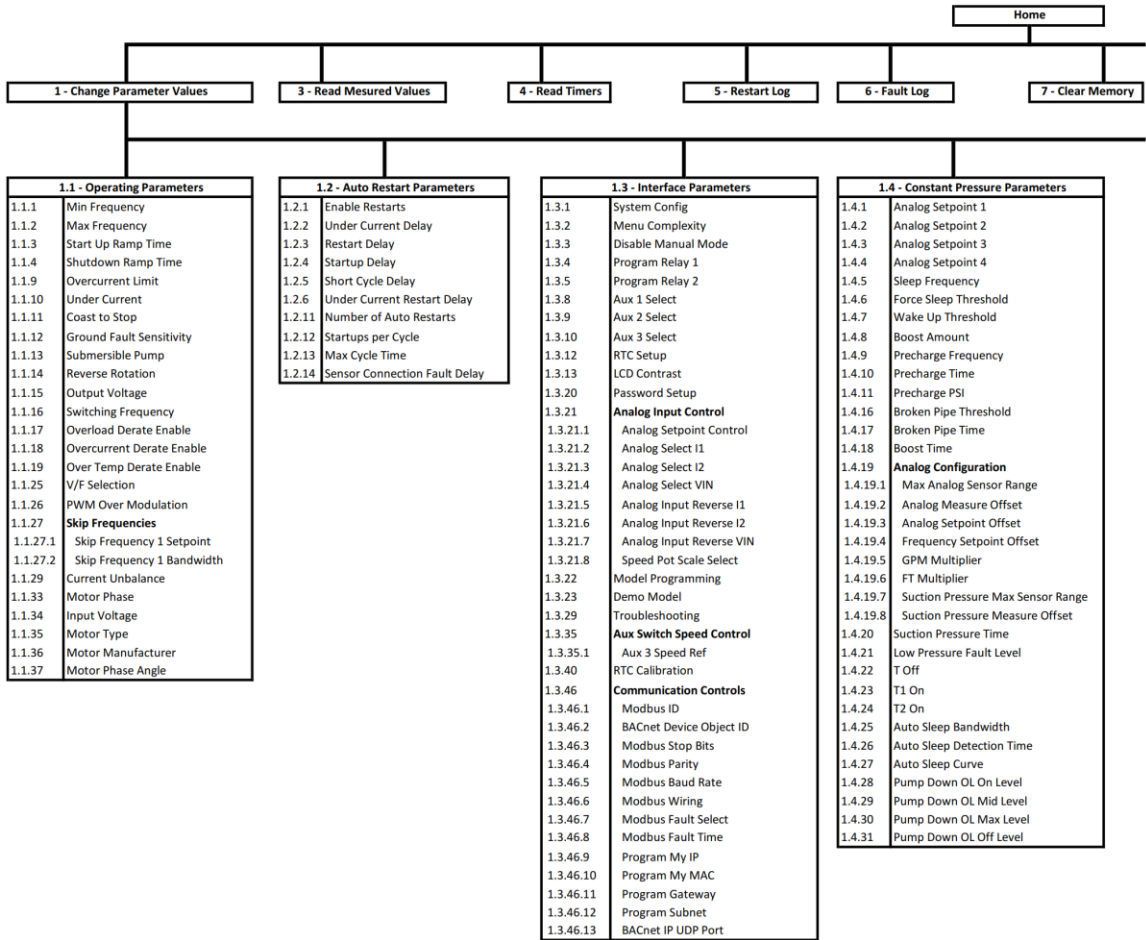

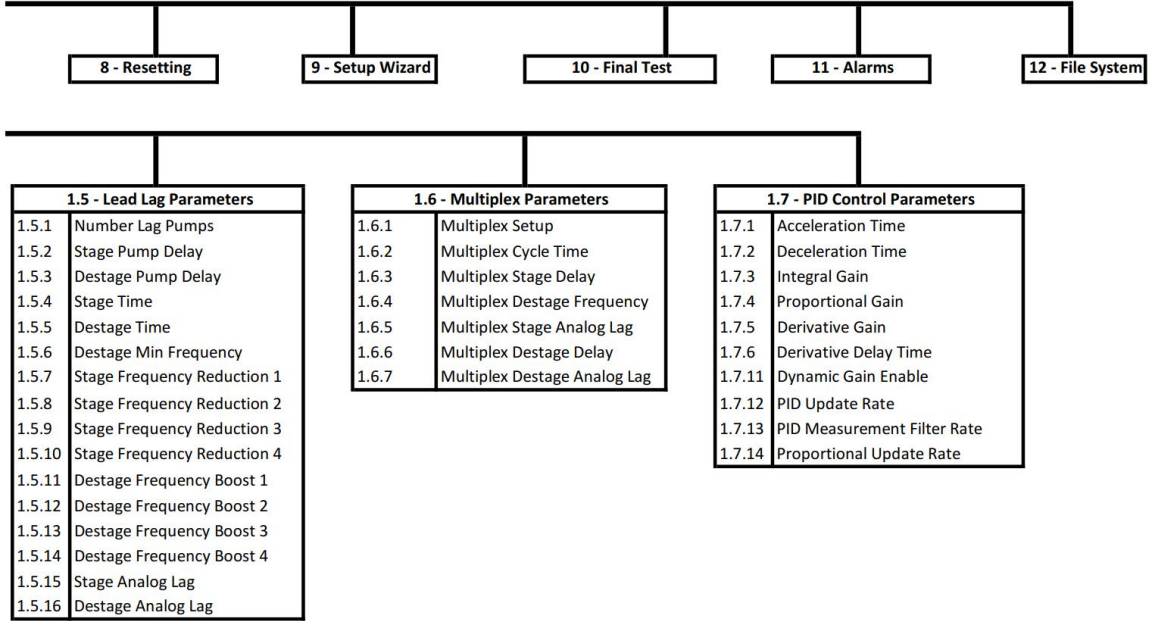

6.15 Parameter Tables

Table 19 – 1.1 Operating Parameters

DISPLAY MESSAGE	DESCRIPTION	DEFAULT [UNITS] (MIN - MAX)
1.1.1 Min Frequency	Minimum output frequency allowed except during startup ramp. When the SUBMERSIBLE PUMP parameter is enabled, frequency will ramp from zero to 1.1.1 MIN FREQUENCY within one second for thrust bearing protection in submersible motors.	30 Hz (5-120)
1.1.2 Max Frequency	Maximum frequency allowed, or target frequency at start-up ramp. This value cannot be lower than 1.1.1 MIN FREQUENCY .	60 Hz (5-120)
1.1.3 Start Up Ramp Time	Time from 1.1.1 MIN FREQUENCY to 1.1.2 MAX FREQUENCY in System Config 0 and 4. Ramp speed is linear. See 1.7.1 ACCELERATION TIME for analog control.	12 sec (1-120)
1.1.4.1 Shut Down Ramp Time	Time to ramp down from 1.1.2 MAX FREQUENCY to 1.1.1 MIN FREQUENCY when the motor receives a STOP command. The ramp time is linear. The factory default setting enables the 1.1.11 COAST TO STOP parameter, which disables the 1.1.4 SHUTDOWN RAMP TIME .	3 sec (1-120)
1.1.9 Overcurrent Limit	Setting for motor overload protection, Trip Class 10 curve. Running below 25% of the rating of the system is not recommended for adequate motor protection.	Drive Rated Current (3 A – 105% Drive Rated Current)
1.1.10 Under Current	Unit shuts down when output current goes below the set value (commonly used for dry well protection). Value can be adjusted while load is running. Drive must be running at 1.1.2 MAX FREQUENCY to engage this protection.	Disabled (0 A – 105% Rated Current)
1.1.11 Coast to Stop	Selects between coast to stop or ramp to stop. Ramp profile is controlled by parameter 1.1.4 DECELERATION PROFILE . YES = coast to stop, NO = ramp to stop.	Yes
1.1.12 Ground Fault Sensitivity	Detects fault between any output line and earth. Sensitivity to fault detection is adjustable to avoid nuisance trips. Lower value equals lower sensitivity to fault detection. (0 = Disabled)	0 (0-9)
1.1.13 Submersible Pump	The frequency will ramp from zero to the value set by parameter 1.1.1 MIN FREQUENCY (default: 30 Hz) within one second to protect the thrust bearing in submersible motors. <i>*Consult your motor manufacturer for the recommended thrust bearing protection frequency.</i> YES = one second ramp time from stop to minimum frequency NO = linear ramp from stop to 1.1.2 MAX FREQUENCY . 1.1.1 MIN FREQUENCY is observed while motor is running.	Yes
1.1.14 Reverse Rotation	Reverses motor direction by changing sequence of output phases. Setting will not change after a factory reset.	Default: Standard ABC Reverse ACB
1.1.15 Output Voltage [§]	Output voltage on main motor terminals. This can only be used to decrease voltage.	115 V: 80-130V 230 V: 100-270V
1.1.16 Switching Frequency [§]	Switching frequency of the IGBT inverter module. Range varies based on the rated HP of the drive. Also known as Carrier Frequency. Setting will not change after a factory reset.	4 kHz (2k-5k)
1.1.17 Overload Derate Enable [§]	During heavy startups, drive frequency will slow down to avoid Output Overload fault. The screen will say OVERLOAD DERATE when conditions apply. Setting can be disabled or set to react SLOW, MEDIUM, or FAST.	Slow (Disabled – Fast)

DISPLAY MESSAGE	DESCRIPTION	DEFAULT [UNITS] (MIN - MAX)
1.1.18 Overcurrent Derate Enable [§]	Drive frequency will slow down to maintain 1.1.9 OVERCURRENT LIMIT . Screen will display OVERCURRENT DERATE when conditions attempt to push the motor beyond programmed overcurrent limit.	Yes
1.1.19 Over Temp Derate Enable [§]	Drive frequency will slow down to avoid drive over temperature fault. Screen will display OVER TEMP DERATE when conditions are overheating the drive.	Yes
1.1.25 V/F Selection [§]	Controls the relationship between voltage and frequency when starting a motor for different applications. Standard: Voltage and frequency increase proportionally, maintaining constant torque. Soft Start 1: Limits voltage during initial ramp to reduce inrush current. Torque is reduced. Soft Start 2: Provides a stronger voltage limitation than Soft Start 1, further reducing inrush current and torque. Soft Start 3: Applies an even more pronounced voltage limitation than Soft Start 2, minimizing inrush current and torque to the greatest extent. Torque Boost: Increases voltage during the initial ramp to boost startup torque.	Standard
1.1.26 PWM Over Modulation [@]	Maximizes the output voltage of an inverter when more voltage is needed than the linear PWM range allows, such as during high load, startup conditions or to overcome voltage drop. Tradeoff: Output wave quality degrades (distorts), increased acoustic noise, and control complexity may increase.	0 % (0-25)
1.1.27 Skip Frequencies [@]	Press ENTER to see the following parameters related to Skip Frequencies.	
1.1.27.1 Skip Frequency 1 Setpoint [@]	Sets the frequency to skip during acceleration and deceleration ramps.	Disabled (0 - 1.1.2 MAX FREQUENCY)
1.1.27.2 Skip Frequency 1 Bandwidth [@]	Sets the width of the frequency band to be skipped. Skipped frequencies will center around 1.1.27.1 SKIP FREQUENCY SETPOINT 1 .	0 Hz (0-300)
1.1.29 Current Unbalance [@]	Percent current unbalance allowed on output phases.	80% (1 – 100)
1.1.33 Motor Phase [§]	Determines if the motor is single-phase or three-phase.	Three-Phase
1.1.34 Input Voltage	Determines the input voltage that will be used. If using 208 V input, select 240 V.	120 V/240 V
1.1.35 Motor Type [§]	Used to select 2-wire or 3-wire motor.	2-wire/3wire
1.1.36 Motor Manufacturer [§]	Select the motor manufacturer to optimize performance. When "Franklin" is chosen, the drive will be compatible with motors containing BIAC switches. Options include: Franklin, Pentek, Grundfoss, AY McDonald, and Other (if "Other" is selected, you will be prompted to select 1.1.33 MOTOR PHASE ANGLE .)	Default: Franklin
1.1.37 Motor Phase Angle [@]	For 3-wire drives only when "Other" is selected for 1.1.36 MOTOR MANUFACTURER . Use this to select Phase Angle based on motor specs. Adjust Phase Angle to reach desired torque.	Based on MOTOR MANUFACTURER /120/180

§ - Parameters are only visible when **1.3.2 MENU COMPLEXITY** is set to **STANDARD**.

@ - Parameters are only visible when **1.3.2 MENU COMPLEXITY** is set to **ADVANCED**.

Table 20 – 1.2 Auto Restart Parameters

DISPLAY MESSAGE	DESCRIPTION	DEFAULT [UNITS] (MIN - MAX)
1.2.1 Enable Restarts	Allows the drive to automatically restart after a fault using last known run command. NO = no auto restarts and unit will initialize in OFF mode YES = Auto mode on initialization and auto restarts allowed	Yes
1.2.2 Under Current Delay	Time 1.1.10 UNDER CURRENT is allowed before unit trips.	4 sec (0-9999)
1.2.3 Restart Delay	Delay before unit restarts after any fault trip other than Under Current. See 1.2.6 UNDER CURRENT RESTART DELAY for more information.	15 sec (0-9999)
1.2.4 Startup Delay	Delay before a restart after an input power OFF/ON cycle. *May be <i>helpful to extend this parameter if the power source is expected to alternate.</i>	0 sec (0-9999)
1.2.5 Short Cycle Delay	Defines the delay time after the drive receives an OFF command. This prevents the drive from re-engaging the motor if a RUN command is issued while the motor is still coasting to a stop. The display will show a countdown in seconds until the drive is ready to run.	3 sec (0-300)
1.2.6 Under Current Restart Delay	Delay before unit restarts after an UNDERCURRENT fault. Commonly used to allow a well to recharge after a dry well condition.	0 min (0-7 days)
1.2.11 Number of Auto Restarts [§]	Number of automatic restarts allowed after a fault trip.	10 (1-9999)
1.2.12 Startups Per Cycle [§]	The number of startups allowed within the time specified under 1.2.13 MAX CYCLE TIME . After the max startups are reached, the drive will wait for 1.2.13 MAX CYCLE TIME to expire or for power to be cycled to attempt another restart.	0 (0-10) 0=Disabled
1.2.13 Max Cycle Time [§]	The maximum amount of time the drive will attempt to complete the startup sequence. Once the limit set by 1.2.13 STARTUPS PER CYCLE is reached, this timer must expire or the drive must be power-cycled before another restart attempt will occur.	01h 00m (0-7 days)
1.2.14 Sensor Connection Fault Delay [@]	Delay when the 4-20mA signal is lost before SENSOR CONN FAIL fault is triggered.	02 sec (0-300)

§ - Parameters are only visible when **1.3.2 MENU COMPLEXITY** is set to **STANDARD**.

@ - Parameters are only visible when **1.3.2 MENU COMPLEXITY** is set to **ADVANCED**.

Table 21 – 1.3 Interface Parameters

DISPLAY MESSAGE	DESCRIPTION	DEFAULT [UNITS] (MIN - MAX)																																							
<p>1.3.1 System Config</p> <p>(see Section 7.5, System Configuration for detailed information)</p>	<p><u>Determines the operating mode of the drive.</u></p> <p>0 = ON/OFF control using AUX1 and AUX2. Both AUX1 and AUX2 must have a contact closure to run.</p> <p>1 = Analog Constant Pressure control using 4-20 mA input.</p> <p>2 = Analog Constant Pressure with redundant sensors and up to two psi setpoints. Control setpoint will change based on the states of AUX3, as shown in the table below.</p> <table border="1" data-bbox="548 407 813 487"> <thead> <tr> <th>AUX3</th> <th>PSI Setpoint</th> </tr> </thead> <tbody> <tr> <td>Off</td> <td>1</td> </tr> <tr> <td>On</td> <td>2</td> </tr> </tbody> </table> <p>3 = Speed Reference I1. Speed control is proportional to 4-20 mA signal applied to I1 terminals.</p> <p>4 = Speed Reference I2. Speed control is proportional to 4-20 mA signal applied to I2 terminals.</p> <p>5 = Speed Pot 0-10VDC. Speed control is proportional to 0-10 VDC signal applied to VIN and COM terminals.</p> <p>6 = Analog constant pressure with HOA and speed pot</p> <table border="1" data-bbox="400 680 964 760"> <thead> <tr> <th>HOA Position</th> <th>AUX3</th> <th>Function</th> </tr> </thead> <tbody> <tr> <td>Auto</td> <td>Off</td> <td>Analog Constant Pressure</td> </tr> <tr> <td>Hand</td> <td>On</td> <td>Speed control</td> </tr> </tbody> </table> <p>7 = Analog constant pressure (4-20 mA only) with dual sensors</p> <table border="1" data-bbox="489 833 874 912"> <thead> <tr> <th>AUX3</th> <th>PSI Setpoint</th> </tr> </thead> <tbody> <tr> <td>Off</td> <td>Analog Constant Pressure</td> </tr> <tr> <td>On</td> <td>Backup Sensor</td> </tr> </tbody> </table> <p>8 = HOA Speed reference selector</p> <table border="1" data-bbox="456 959 907 1088"> <thead> <tr> <th>AUX1</th> <th>AUX3</th> <th>Function</th> </tr> </thead> <tbody> <tr> <td>On</td> <td>On</td> <td>0-10 VDC Speed Reference</td> </tr> <tr> <td>On</td> <td>Off</td> <td>I1 4-20 mA Speed Reference</td> </tr> </tbody> </table> <p>9 = Pump Down Open Loop. Open loop speed control based on fluid level, using either a 4-20 mA or 0-10VDC level transducer. Fluid level determines motor speed.</p> <p>10 = Modbus with HOA and Speed Pot.</p> <table border="1" data-bbox="451 1209 912 1289"> <thead> <tr> <th>HOA Position</th> <th>AUX3</th> <th>Function</th> </tr> </thead> <tbody> <tr> <td>Auto</td> <td>Off</td> <td>Modbus control</td> </tr> <tr> <td>Hand</td> <td>On</td> <td>Speed control</td> </tr> </tbody> </table> <p>See Section 7.5, for more details.</p>	AUX3	PSI Setpoint	Off	1	On	2	HOA Position	AUX3	Function	Auto	Off	Analog Constant Pressure	Hand	On	Speed control	AUX3	PSI Setpoint	Off	Analog Constant Pressure	On	Backup Sensor	AUX1	AUX3	Function	On	On	0-10 VDC Speed Reference	On	Off	I1 4-20 mA Speed Reference	HOA Position	AUX3	Function	Auto	Off	Modbus control	Hand	On	Speed control	<p>0 (0-6)</p>
AUX3	PSI Setpoint																																								
Off	1																																								
On	2																																								
HOA Position	AUX3	Function																																							
Auto	Off	Analog Constant Pressure																																							
Hand	On	Speed control																																							
AUX3	PSI Setpoint																																								
Off	Analog Constant Pressure																																								
On	Backup Sensor																																								
AUX1	AUX3	Function																																							
On	On	0-10 VDC Speed Reference																																							
On	Off	I1 4-20 mA Speed Reference																																							
HOA Position	AUX3	Function																																							
Auto	Off	Modbus control																																							
Hand	On	Speed control																																							
<p>1.3.2 Menu Complexity</p>	<p>Determines what parameters are shown or hidden. Simple will be adequate for most applications but more complex programming requires additional parameters to be visible. Parameters visible in Standard mode will be followed by "\$" on the display. Parameters visible in Advanced mode will be followed by "@" on the display.</p>	<p>Simple</p>																																							

DISPLAY MESSAGE	DESCRIPTION	DEFAULT [UNITS] (MIN - MAX)
1.3.3 Disable Manual Mode	Disables manual operation of the drive through the keypad. Operating states are limited to AUTO and OFF. YES = MANUAL mode disabled.	Yes
1.3.4 Program Relay 1	<p>Programmable normally open / normally closed relay. Control Terminals 1NC, 1NO, and COM. The relay can be programmed to change state for the following conditions:</p> <p>0 = System Fault: State will change when drive faults.</p> <p>1 = Lag Pump: Lag/Duplex is controlling the relay.</p> <p>2 = Modbus Control: Customer Modbus is controlling the relay. Modbus Control commands will override current settings except when configured to state 1 or 7.</p> <p>3 = Pump Fault: e.g. motor overload, under current, etc.</p> <p>4 = Output Active: Relay activates when VFD frequency is greater than zero.</p> <p>5 = Damper: Relay activates when AUX1 is closed in the Auto run-mode.</p> <p>6 = Pre-lube Oiler: Relay energizes when a RUN command is given in either Manual or Auto mode. The drive will count down from 1.3.30 OILER ON-DELAY TIMER and then begin outputting. Once the drive reaches 1.1.1 MIN FREQUENCY, the relay will de-energize.</p> <p>7 = Jockey Pump. Relay will not participate in lead/lag or multiplex pump control. Instead, relay will change states when motor frequency is greater than 0, and open when it is exactly 0.</p> <p>This setting is only available for Program Relay 1.</p>	0 (0-7)
1.3.5 Program Relay 2	Programmable normally open / normally closed relay. Control Terminals 2NO, and COM. See Parameter 1.3.4 PROGRAM RELAY 1 above for description of values.	0 (0-6)
1.3.8 AUX1 Select 1.3.9 AUX2 Select	<p>Programmable digital inputs. Generally used for motor Run/Stop control.</p> <p>0 = RUN/STOP (On = RUN, Off = STOP)</p> <p>1 = RUN/STOP (Off = RUN, On = STOP)</p> <p>2 = Always in Run Mode</p> <p>3 = Latching Relay. When the connection between the AUX terminal and COM is opened the drive will stop the motor and display a fault on the screen. The motor will remain stopped even if the connection is closed. The fault must be cleared by pressing the ENTER key.</p> <p>The function of these inputs can change when certain System Configuration settings are chosen. See Section 7.5.</p>	2 (0-3)

DISPLAY MESSAGE	DESCRIPTION	DEFAULT [UNITS] (MIN - MAX)
1.3.10 AUX3 Select	<p>Programmable digital inputs. Generally used for motor Run/Stop control.</p> <p>0 = RUN/STOP (On = RUN, Off = STOP) 1 = RUN/STOP (Off = RUN, On = STOP) 2 = Always in Run Mode 3 = Latching Relay. When the connection between the AUX terminal and COM is opened the drive will stop the motor and display a fault on the screen. The motor will remain stopped even if the connection is closed. The fault must be cleared by pressing the ENTER key. 4 = Reverse Rotation. When the circuit changes states, the motor will ramp down for (30 seconds + 1.25 SHORT CYCLE DELAY), then ramp back up in the opposite rotation. When open, the drive will run in standard rotation, closed will run in reverse rotation. 5 = Reverse Latching Relay. When the connection between the AUX terminal and COM is closed the drive will stop the motor and display a fault on the screen. The motor will remain stopped even if the connection is opened. The fault must be cleared by pressing the ENTER key. 6 = Speed Reference. Used in conjunction with 1.3.35 AUX SWITCH SPEED CONTROL, multiple speeds can be programmed and controlled based on the open/closed state of AUX3. 7 = Fireman's Override Mode Closing the AUX will override current settings to run the load at Max Frequency. This will bypass all VFD and motor protections and run the drive until failure, to assist with building evacuation. All other external run/stop commands including from the keypad will be ignored. 8 = Fireman's Override Reverse. Closing the AUX will override current settings to run the load in reverse of normal operation at Max Frequency. This will bypass all VFD and motor protections and run the drive until failure, to assist with building evacuation. All other external run/stop commands including from the keypad will be ignored. 9 = System Config Special Function. This will automatically be set when 1.3.1 SYSTEM CONFIG is set for 2, 3, 5, and 6. See Section 7.5 for details.</p> <p>The function of these inputs can change when certain System Configuration settings are chosen. See Section 7.5.</p>	2 (0-7)
1.3.12 RTC Setup	<p>Real-Time Clock MO/DD/YR H:M:SS Enter button moves the character to the right, use UP and DOWN keys to select the number.</p>	Date and Time
1.3.13 LCD Contrast	Used to adjust the contrast of the graphic display.	40 (30-59)
1.3.20 Password Setup \$	<p>Allows keypad function to be password protected. When keypad is locked, it will prompt for a user-defined four-digit password. A parameter value of "0000" disables password protection. Each digit can go from 0 to F: 0, 1, 2, 3, 4, 5, 6, 7, 8, 9, A, B, C, D, E, F. Press enter to select the next digit. Setting will not change after a factory reset.</p>	No Default (User Defined)

1.3.21 Analog Input Control ^s	Press ENTER to see the following parameters related to Analog Input Control.	
1.3.21.1 Analog Setpoint Control	Allows a dynamic control setpoint, determined by an analog input. Disabled: Analog input does not affect the control setpoint. Analog Control: The analog input determines the control setpoint. Frequency: The analog input determines the frequency setpoint.	Disabled
1.3.21.2 Analog Select I1	Determines how the I1 analog input is used. Measurement: I1 is used as feedback to control the PID loop for constant pressure, flow control, etc. Setpoint Control: I1 is used to set the control setpoint. Backup Measurement: I1 acts as a backup measurement in case the primary sensor fails. Backup Setpoint Control: I1 acts as a backup setpoint control in case the primary setpoint control fails.	Disabled
1.3.21.3 Analog Select I2	Same options as 1.3.21.2 ANALOG SELECT I1 above, but for I2.	Disabled
1.3.21.4 Analog Select VIN	Same options as 1.3.21.2 ANALOG SELECT I1 above, but for 10 VDC input.	Disabled
1.3.21.5 Analog Input Reverse I1	Reverses the scale of the I1 input.	No
1.3.21.6 Analog Input Reverse I2	Reverses the scale of the I2 input.	No
1.3.21.7 Analog Input Reverse VIN	Reverses the scale of the 10 VDC input.	No
1.3.21.8 Speed Pot Scale Select	Changes the frequency range that the speed pot operates over. 0 – Max Frequency: Speed will ramp linearly from zero to 1.1.2 MAX FREQUENCY based on the analog input value. Min Frequency – Max Frequency: Speed will jump to 1.1.1 MIN FREQUENCY and then ramp linearly to 1.1.2 MAX FREQUENCY based on the analog input value.	0 – Max Freq
1.3.22 Model Programming [@]	In rare instances, a model will need to be changed. This SHOULD ONLY be used under the direction of Phase Technologies.	Set by Factory
1.3.23 Demo Model [@]	Allows unit to be programmed as a demo model so that they do not switch IGBTs and do not fault for input faults. This SHOULD ONLY be used under the direction of Phase Technologies. Requires factory password to unlock.	No
1.3.29 Troubleshooting [@]	Used to access Advanced Parameters and clear memory. 0 – 3 = Reserved for factory use 4 = Clear Run Timers 5 = Clear Fault Log	0 (0-5)
1.3.35 Aux Switch Speed Control [@]	Press ENTER to see the following parameters related to AUX Switch Speed Control.	
1.3.35.1 Aux 3 Speed Ref	The speed the drive will run at when only AUX3 is closed.	60 Hz (5-300)
1.3.40 RTC Calibration [@]	Used to adjust the RTC drift by seconds per day.	0 (-31-31)

1.3.46 Communication Controls @	Press ENTER to see the following parameters related to Modbus.	
1.3.46.1 Modbus ID	Address of the drive for a Modbus network.	1 (0-247)
1.3.46.2 BACnet Device Object ID	Used to set the ID of the device object.	20000 (20000-20500)
1.3.46.3 Modbus Stop Bits	Number of bits transmitted after each character to detect the end of the character.	1 (1-2)
1.3.46.4 Modbus Parity	Sets how the parity of the character's data frame is set.	None (Odd-Even)
1.3.46.5 Modbus Baud Rate	Serial baud rate or the rate at which information is transferred.	19200 (2400- 57600)
1.3.46.6 Modbus Wiring	Select between using 2-wire or 4-wire Modbus configuration.	4-wire
1.3.46.7 Modbus Fault Select	Select how the drive responds when serial communication is lost. Options are disabled, to fault, or stop the output of the VFD without faulting.	Disabled
1.3.46.8 Modbus Fault Time	In seconds. Select how long serial communication loss persists before Modbus Fault Selection state takes effect.	0 sec (0-120)
1.3.46.9 Program My IP	Sets the IP address of the drive.	N/A
1.3.46.10 Program My MAC	Sets the MAC address of the drive. The default is unique for all units.	N/A
1.3.46.11 Program Gateway	Sets the Gateway IP for the network.	N/A
1.3.46.12 Program Subnet	Sets the Subnet mask for the network.	N/A
1.3.46.13 BACnet IP UDP Port	Sets the port used for BACnet communication. Screen will display numeric value and hexadecimal equivalent.	47808 (47808-47823)

\$ - Parameters are only visible when **1.3.2 MENU COMPLEXITY** is set to **STANDARD**.

@ - Parameters are only visible when **1.3.2 MENU COMPLEXITY** is set to **ADVANCED**.

 **Programming Tip**

Constant Pressure parameters are only displayed when System Configuration has been set for constant pressure. The parameter **1.3.1 SYSTEM CONFIG** is in the **1.3 INTERFACE PARAMETERS** sub-menu. See **Table 21** for details.

Table 22 – 1.4 Constant Pressure Parameters

DISPLAY MESSAGE	DESCRIPTION	DEFAULT [UNITS] (MIN - MAX)
1.4.1 Analog Setpoint 1	For PID controlled systems only. This sets the level at which the pressure/flow/level will be controlled. Must be set within the range of the 4-20 mA transducer. Make sure that 1.4.19.1 ANALOG SENSOR RANGE is set to the maximum value of the sensor you are using. Up to four psi set points can be used depending upon the System Configuration. See Section 7.5 for details.	50 psi (0 – 500) 200 GPM (0.1 – 3,200) 5 ft (0 – 5,000)
1.4.2 Analog Setpoint 2		
1.4.3 Analog Setpoint 3		
1.4.4 Analog Setpoint 4		
1.4.5 Sleep Frequency	This parameter value is <u>added</u> to the frequency set by 1.1.1 MIN FREQUENCY . The combined value is the frequency at which drive will enter sleep mode, after a 6 second delay, when pressure is controlled at the setpoint, and after the minimum ON time has been satisfied.	7 Hz (0-30)
1.4.6 Force Sleep Threshold	This value is added to the primary setpoint, and the combined total represents the pressure, flow, or level at which the drive will stop the motor. The motor will automatically restart when the measured parameter decreases to the value specified by parameter 1.4.7 WAKE UP THRESHOLD .	20 psi (0-500) 100 GPM (0.1–32,000) 1 ft (0.01–10,000)
1.4.7 Wake Up Threshold	This controls amount of decrease below 1.4.1 ANALOG SETPOINT before the system will “wake” and start the motor. e.g. if this is set to 5 and motor turns off at 50 psi, motor will restart at 45 psi.	5 psi (0-50) 100 GPM (0.1 – 32,000) 1 ft (0 – 5,000)
1.4.8 Boost Amount	The parameter value specifies an increase above the setpoint before sleep mode.	0 psi (0-100) 0 GPM (0-32,000) 0 ft (0-5,000)
1.4.9 Precharge Frequency	Sets the maximum frequency applied to the motor during the precharge interval.	30 Hz (1-120)
1.4.10 Precharge Time	Sets the maximum time for precharge regardless of any sensor inputs. A setting of zero disables the precharge mode.	0 min (0-30,000)
1.4.11 Precharge PSI	Used only for analog CP systems. Precharge will be terminated when pressure reaches this setpoint. Should be set less than 1.4.1 ANALOG SETPOINT 1 .	20 psi (0-200)
1.4.16 Broken Pipe Threshold [§]	Level at which drive will determine that there is a broken pipe. Value of zero disables this feature.	0 psi (0-150) 0 GPM (0.1-3,200) 0 ft (-50-50)
1.4.17 Broken Pipe Time [§]	Specifies the time that the system must remain below the value set by 1.4.16 BROKEN PIPE THRESHOLD to trigger a fault. A value of 0 disables Broken Pipe protection.	0 min (0-9999)
1.4.18 Boost Time [§]	The maximum amount of time the drive will attempt to boost. After reaching Boost Time, the drive will go to sleep.	3 sec (0-60)

DISPLAY MESSAGE	DESCRIPTION	DEFAULT [UNITS] (MIN - MAX)
1.4.19 Analog Config [§]	Press ENTER to see the following parameters related to Analog Configurations.	
1.4.19.1 Max Analog Sensor Range	This should be set to the maximum value of the 4-20 mA transducer being used for analog control i.e. if the transducer has a range of 0-150, this parameter should be set to 150. This parameter is critical for accurate control.	150 psi (50-500) 400 GPM (0.1-3,200) 10 ft (0.01-100)
1.4.19.2 Analog Measure Offset	Used to calibrate the analog measurement from a 4-20 mA if a manual measurement is not equal to VFD reading. For example, if VFD reads 40 psi, but manual measurement shows 50 psi, this should be set to +10.	0 psi (-50 – 50) 0 GPM (-1,000-1000) 0 ft (-50-50)
1.4.19.3 Analog Setpoint Offset	Used to calibrate the reading that the VFD registers from a 4-20 mA transducer when ANALOG SELECT I1/I2 is set to Setpoint Control. For example, if the intended setpoint is 50 psi, but the VFD reads the setpoint is 40 psi, 1.4.38.7 PSI SETPOINT OFFSET should be set to +10.	0 psi (-50 – 50) 0 GPM (-1,000-1,000) 0 ft (-50-50)
1.4.19.4 Frequency Setpoint Offset	Used to calibrate the Frequency Setpoint if the drive reading differs from the intended value. For example, if the intended Frequency setpoint is 55 Hz but the drive runs at 52 Hz, this parameter should be set to +3.	0 Hz (-30 – 30)
1.4.19.5 GPM Multiplier	Moves the decimal to change the scale of the sensor and setpoint being used.	0.1 (0.01-1)
1.4.19.6 FT Multiplier		0.01 (0.01-1)
1.4.19.7 Suction Pressure Max Sensor Range	Should be set to the maximum value of the 4-20 mA suction pressure transducer being used for analog control i.e. if the transducer has a range of 0-150, this parameter should be set to 150.	150 psi (50-500)
1.4.19.8 Suction Pressure Measure Offset	Used to calibrate the suction pressure analog measurement from a 4-20 mA if a manual measurement is not equal to VFD reading. For example, if VFD reads 40 psi, but manual measurement shows 50 psi, this should be set to +10.	0 psi (-50 – 50)
1.4.20 Suction Pressure Time [§]	The time at which the pressure must remain below 1.4.21 LOW PRESSURE FAULT LEVEL before triggering a fault.	0 sec (0-1800)
1.4.21 Low Pressure Fault Level [§]	Used only for transducers wired to I_2. The pressure setting where any lower value will trigger a fault.	15 psi (0-200)
1.4.22 T OFF [@]	Used to prevent short cycling in CP systems. If the motor was off during the last cycle for a period greater than 1.4.22 TOFF , the minimum on time of the motor is 1.4.23 T1 ON . If the motor was off for a period less than 1.4.22 TOFF , the minimum on time of the motor is 1.4.24 T2 ON . Default values give a minimum cycle time of about 1 minute.	30 sec (0-9999)
1.4.23 T1 ON [@]	See 1.4.22 TOFF above. Must be set less than 1.4.24 T2 ON .	15 sec (0-1000)
1.4.24 T2 ON [@]	See 1.4.22 TOFF above. Must be greater than 1.4.25 T1 ON .	60 sec (0-1000)
1.4.25 Auto Sleep Bandwidth [@]	Expressed as a percentage of the setpoint, this parameter determines the level at which the Auto Sleep feature can activate. For example, if set to 1.5% and the setpoint is 50 psi, Auto Sleep can activate within approximately 0.75 psi of the setpoint, i.e., between 49.25 psi and 50.75 psi.	1.5% (0-100)
1.4.26 Auto Sleep Detection Time [@]	The length of time the analog measurement (psi/level) is within 1.4.25 AUTO SLEEP BANDWIDTH before Auto Sleep activates.	3 sec (1-300)
1.4.27 Auto Sleep Curve [@]	Sets how quickly frequency decreases during Auto Sleep. A higher number will force frequency to fall more slowly.	18 (1-999)
1.4.28 Pumpdown OL On Level	During Open Loop pump down control, the level where the pump turns on and runs at 1.1.1 MIN FREQUENCY .	4 ft (0-100)
1.4.29 Pumpdown OL Mid Level [@]	During Open Loop pump down control, the level where the pump runs at mid speed. Can be disabled if linear control is desired.	Disabled (0-100 ft)

1.4.30 Pumpdown OL Max Level	During Open Loop pump down control, the level where the pump turns runs at 1.1.2 MAX FREQUENCY .	6 ft (0 – 100)
1.4.31 Pumpdown OL Off Level	During Open Loop pump down control, the level where the pump turns off.	3 ft (0-100)

§ - Parameters are only visible when **1.3.2 MENU COMPLEXITY** is set to **STANDARD**.

@ - Parameters are only visible when **1.3.2 MENU COMPLEXITY** is set to **ADVANCED**.

 **Programming Tip**

Lead/Lag Parameters are only displayed when **1.3.1 SYSTEM CONFIGURATION** has been set for Constant Pressure AND when **1.3.2 MENU COMPLEXITY** has been set to **Standard** or **Advanced**. More information on can be found in **Section 8.11**.

Table 23 – 1.5 Lead/Lag Parameters

DISPLAY MESSAGE	DESCRIPTION	DEFAULT [UNITS] (MIN - MAX)
1.5.1 Number Lag Pumps §	Sets the number of auxiliary pumps that are connected to the relays on the control board. The relays will be called for in order, starting with Relay 1.	0 (0-2)
1.5.2 Stage Pump Delay §	Delay before the system will call for a pump to be staged in.	4 sec (0-3600)
1.5.3 Destage Pump Delay §	Delay before the system will destage a pump when pressure is maintained at 1.1.1 MIN FREQUENCY of the primary pump.	4 sec (0-3600)
1.5.4 Stage Time §	This is the interval for which the system will reduce its frequency by 1.5.7 – 1.5.10 STAGE FREQUENCY REDUCTION .	4 sec (0-3600)
1.5.5 Destage Time §	This is the interval for which the system will increase its frequency by 1.5.11 – 1.5.14 DESTAGE FREQUENCY BOOST .	4 sec (0-3600)
1.5.6 Destage Min Frequency §	1.1.1 MIN FREQUENCY of primary pump plus this amount to destage.	45 Hz (Min Freq – Max Freq)
1.5.7 Stage Freq Reduction 1 §	Reduces frequency of primary pump for the duration of the 1.5.4 STAGE TIME when the specified pump is staged in.	5 Hz (0-120)
1.5.8 Stage Freq Reduction 2 §		5 Hz (0-120)
1.5.9 Stage Freq Reduction 3 §		5 Hz (0-120)
1.5.10 Stage Freq Reduction 4 §		5 Hz (0-120)
1.5.11 Destage Freq Boost 1 §	Increases frequency of primary pump for the duration of the DESTAGE TIME when the specified pump is destaged.	5 Hz (0-120)
1.5.12 Destage Freq Boost 2 §		5 Hz (0-120)
1.5.13 Destage Freq Boost 3 §		5 Hz (0-120)
1.5.14 Destage Freq Boost 4 §		5 Hz (0-120)
1.5.15 Stage Analog Lag §	Allows the system to fall below the control psi by this amount before the system starts counting 1.5.4 STAGE TIME . Assumes max Hz.	6 PSI (0-200) 31 GPM (0.1-3,200) 0.6 ft (0-500)

§ - Parameters are only visible when **1.3.2 MENU COMPLEXITY** is set to **STANDARD**.

 **Programming Tip**

Multiplex Parameters are only displayed when **1.3.1 SYSTEM CONFIGURATION** has been set for constant pressure AND when **1.3.2 MENU COMPLEXITY** has been set to **Standard** or **Advanced**. More information on can be found in **Section 8.11**.

Table 24 – 1.6 Multiplex Parameters

DISPLAY MESSAGE	DESCRIPTION	DEFAULT [UNITS] (MIN - MAX)
1.6.1 Multiplex Setup [§]	<p>1.3.2 MENU COMPLEXITY must be set to ADVANCED. Walks through setup procedure for programming Multiplex operation, which will run one pump for a set period of time before rotating to the next. Up to five systems can be programmed to operate with this setup. Each drive must be programmed for Constant Pressure, then for Multiplex:</p> <ol style="list-style-type: none"> 1. Multiplex Type (Disabled, Modbus, or AUX + Relays). This determines how the units will communicate to each other. 2. Multiplex ID & Default Role. Determines the ID of each Multiplex system. The Master unit should be set to "1" and each subsequent system should be set to unique values from "2" to "5". 3. Multiplex Cycle Time. Determines how long each pump will run before rotating to the next. 4. Share Transducer. Select whether you will connect one pressure transducer to the Master drive or will connect a pressure transducer to each drive. <p>After completing this setup on each drive, return to the Master drive and press ENTER to complete setup. See Section 8.12 for complete details.</p>	-
1.6.2 Multiplex Cycle Time [§]	Determines the run time for each cycle of both primary and secondary pump, in clock time, NOT running time. 1.6.1 NUMBER MULTIPLEX SYSTEMS must be set above 0 for this to be operational.	1 day (0-9999 days)
1.6.3 Multiplex Stage Delay [§]	Delay before the system will call for a pump to be staged in, when the current drive cannot maintain setpoint.	30 sec (0-1 hour)
1.6.4 Multiplex Destage Frequency [§]	1.1.1 MIN FREQUENCY of primary pump plus this amount to destage.	Min Frequency + 22 Hz (Min Freq – Max Freq)
1.6.5 Multiplex Stage Analog Lag [§]	Allows the system to fall below the control setpoint by this amount before the system starts counting 1.6.3 MULTIPLEX STAGE DELAY . Assumes max Hz.	Setpoint – 6 PSI (0-200) Setpoint – 35 GPM (0.1-3,200) Setpoint – 0.6 ft (0-500)
1.6.6 Multiplex Destage Delay [@]	Delay before the system will destage a pump when pressure is maintained at 1.1.1 MIN FREQUENCY of the primary pump.	10 sec (0-1 hour)
1.6.7 Multiplex Destage Analog Lag [@]	Allows the system to rise above the control setpoint by this amount before the system starts counting 1.6.6 MULTIPLEX DESTAGE DELAY . Assumes frequency is below 1.6.4 MULTIPLEX DESTAGE FREQUENCY .	Setpoint + 0 PSI (0-200) Setpoint + 0.1 GPM (0.1-3,200) Setpoint + 0 ft (0-500)

§ - Parameters are only visible when **1.3.2 MENU COMPLEXITY** is set to **STANDARD**.

@ - Parameters are only visible when **1.3.2 MENU COMPLEXITY** is set to **ADVANCED**.

 **Programming Tip**

PID Control Parameters are only displayed when **1.3.1 SYSTEM CONFIGURATION** has been set for one of the PID loop control schemes (Constant Pressure, Flow Control, Tank Level Control, Pump Down Control, or Suction Pump Control).

Table 25 – 1.7 PID Control Parameters

DISPLAY MESSAGE	DESCRIPTION	DEFAULT [UNITS] (MIN - MAX)
1.7.1 Acceleration Time	Defines the ramp up time from 1.1.1 MIN FREQUENCY to 1.1.2 MAX FREQUENCY during analog control.	12 sec (1-120)
1.7.2 Deceleration Time	Defines the ramp down time from 1.1.2 MAX FREQUENCY to 1.1.1 MIN FREQUENCY during analog control.	5 sec (1-120)
1.7.3 Integral Gain	Multiplier for the integral term in PI control of analog CP. Results in faster or slower correction of steady-state errors. (It responds to the sum of past errors averaged over time) <i>Example: pressure consistently lagging behind setpoint, the longer a system cycles the closer pressure gets to setpoint</i>) A higher number will result in a faster response time. <i>*Changes should be made in small increments, or the system may become unstable.</i>	12 (0-100)
1.7.4 Proportional Gain @	Multiplier for the analog error signal in an analog CP system. Results in faster or slower correction to the real-time error. (It provides immediate correction, helping the system respond quickly to changes) A higher value will make the control respond faster. <i>*Changes should be made in small increments, or the system may become unstable.</i>	5 (1 – 60)
1.7.5 Derivative Gain @	It helps anticipate potential future errors—such as overshoot and oscillation—by evaluating the real-time rate of change of the psi, flow, level, speed and dampening the drive response. <i>*Changes should be made in small increments, derivative gain can amplify noise in your analog signal and cause the system to become unstable.</i>	0 (0-100)
1.7.6 Derivative Delay Time @	Reduces the impact of high-frequency noise on the derivative action, 1.7.5 DERIVATIVE GAIN. It introduces a small delay, or filtering, to the derivative calculation that prevents it from reacting too strongly to rapid, noise-induced fluctuations. This parameter disables the derivative term during initial operation for the time set. This can be useful if the measured analog signal changes rapidly during startup.	5 sec (0-300)
1.7.11 Dynamic Gain Enable @	Allows the control system to automatically adjust its gains in real-time, optimizing performance and stability under varying conditions.	No
1.7.12 PID Update Rate @	Determines how frequently the control algorithm (PID loop) recalculates and updates its output based on the psi, flow, level, speed in relation to the setpoint. Measured in milliseconds, a higher value will cause the PID loop to react slower to change.	3 (3-100)
1.7.13 PID Measurement Filter Rate @	Controls how fast the PID measurements are filtered before being used by the PID loop. A higher filter rate (faster response) allows the PID loop to react more quickly to measurement changes while a lower rate (slower response) smooths out rapid fluctuations in noise, providing a more stable measurement for the PID loop. <i>Increasing this value will result a faster response, but too high may filter out necessary data points.</i>	75 (50-200)
1.7.14 Proportional Update Rate @	Controls how often the proportional term of the PID control is updated based on the real-time error. A higher value will result in a slower response.	1 (1 – 300)

\$ - Parameters are only visible when **1.3.2 MENU COMPLEXITY** is set to **STANDARD**.

@ - Parameters are only visible when **1.3.2 MENU COMPLEXITY** is set to **ADVANCED**.

7 Operation & Control Methods

7.1 Commissioning the Unit

Initial Operation and Setup Recommendations

- Before starting regular operation, it is advisable to verify the operating status of the drive and its load:
- **Initial Operation**
 - Before proceeding, verify the following:
 1. The unit is securely mounted to the designated surface.
 2. The input terminals are properly connected to an appropriate power source.
 3. A motor with the correct rating is connected to the output terminals.
 4. The motor is securely mounted and properly secured.
- **Setup Wizard**
 - During the initial startup of the unit (or after restoring all parameters to factory defaults), the drive will prompt you to either initiate or skip the Setup Wizard.
 - The Setup Wizard provides a quick and guided setup process for common control schemes, including:
 - Constant Pressure Control
 - Flow Control
 - Tank Level Control
 - Pump Down Control
 - Suction Pump Control
 - Using the UP and DOWN keys, select the desired control scheme, then press **ENTER** to proceed.
- If you prefer to configure the drive manually, press **HOME** to skip the wizard and proceed directly to manual programming.

7.2 VFD Setup Procedure

Initial Start-Up Procedure

- **Remote ON/OFF Functionality:**

If remote or automatic ON/OFF control is required, connect the remote switch leads to the **AUX1** and **COM** terminals. An additional remote switch or jumper wire can be connected between **AUX2** and **COM** terminals. The jumper wires between **AUX1 to COM** and **AUX2 to COM** are pre-installed by the factory; remove them as needed for pressure switches or remote ON/OFF switches.
- **Constant Pressure System Connection:**

For operation of a constant pressure (CP) water system, connect the pressure sensors to the appropriate control terminals. Refer to **Section 6.5, System Configuration**, and **Section 7, Constant Pressure Systems**, for detailed instructions.
- **Power Application:**

Apply power to the drive by turning on the input circuit breaker or disconnect switch.

- **Startup Sequence:**
The graphic display will automatically scroll through several startup messages.
- **Start-Up Wizards**
Select from available set up wizards or hit home to bypass the wizards and use **1.1 CHANGE PARAMETER VALUES** to set the necessary parameters for operation.

7.3 Ground Fault Sensitivity

- These drives are equipped with a feature to detect ground faults between any of the output lines and earth. If a ground fault is strong enough to activate the **1.1.12 GROUND FAULT SENSITIVITY** parameter, the drive will prevent the IGBTs from switching, effectively disabling output power. However, this protection does not guarantee complete safety from damage in all situations.
- In the event of a ground fault, **immediately disconnect the input power** to prevent potential damage or safety hazards.
Note that long motor leads and the use of a dV/dt filter can sometimes cause false ground fault indications. If a megger test does not indicate a ground fault, it may be necessary to **reduce the sensitivity** by lowering the value of **1.1.12 GROUND FAULT SENSITIVITY**.

⚠ CAUTION: Before connecting the motor to the output terminals, thoroughly inspect all output lines for line-to-ground faults using a megger. Be aware that there is a direct path through the drive circuitry for ground fault currents, which can be triggered when power is applied to the input terminals—even if the output switches are not engaged. These fault currents can cause significant damage to the drive circuitry and are not covered under warranty.

⚠ WARNING! The default operating mode when the unit is energized is OFF. If the parameter ENABLE RESTARTS has been set to allow restarts, the unit will energize in AUTO mode. If the external controls are calling for a motor run condition, the motor will start. Make sure either external controls are off before energizing the input, or as soon as the unit has initialized, push the STOP/OFF key until **OFF** appears on the display. Refer to **Section 5.1, Using the Keypad and Display**, for instructions on operating the keypad.

7.4 Motor Overload Protection

- These drives feature adjustable solid-state motor overload protection, which is configured according to a Class 10 trip curve. To set the motor overload protection, use the keypad and display to navigate to the appropriate menu item and adjust the overload settings accordingly.
 - A **Class 10** device is designed to trip (shut off power) **within 10 seconds** when subjected to a current that is **6 times** (or 600%) the motor's rated full-load current (FLC).
- **Thermal Memory and Thermal Memory Retention**
The motor overload protection is equipped with thermal memory and thermal memory retention capabilities.
 - **Thermal Memory** is the ability of an overload protective system to approximate the heating cooling of a protected motor during operation.
 - **Thermal Memory Retention** helps ensure that overload protection accurately reflects the motor's thermal condition, even after periods of inactivity or power loss, thereby improving protection reliability and reducing nuisance trips.

⚠ CAUTION: Do not attempt to restart the motor immediately after a motor overload fault. The motor overload protection system uses a timer to approximate motor cooling and may trigger an immediate overload fault if the motor is restarted too soon.

- **Setting Motor Overload Protection with Keypad**

To set motor overload protection with the keypad, navigate to the Main Menu item **1 CHANGE PARAMETER VALUES** → **1.1 OPERATING PARAMETERS** → **1.1.9 OVERCURRENT LIMIT**.

7.5 System Configuration

- The drive is capable of operating various system types, including constant pressure water systems and simple ON/OFF control from remote switches. To ensure proper operation, it is essential to select the correct system configuration setting corresponding to your specific control system.
- System configuration is set by navigating to the keypad Main Menu item **1 CHANGE PARAMETER VALUES** → **1.3 INTERFACE PARAMETERS** → **1.3.1 SYSTEM CONFIG**. Refer to **Section 6.8, Changing Parameter Values**, and **Table 21, Interface Parameters**, for detailed instructions.

1.3.1 System Configuration = 0: Basic RUN/STOP operation

This is the factory default configuration for basic operation, enabling RUN/STOP control of the motor in AUTO mode via a dry contact on **AUX1** and/or **AUX2**. Both **AUX1** and **AUX2** must have a contact closure to initiate motor operation. **AUX3** can be enabled if additional control is required.

1.3.1 System Configuration = 1: Analog Constant Pressure.

Use this setting to operate analog constant pressure systems with a 4-20 mA transducer. Refer to **Section 8.9, Analog Constant Pressure Systems**, for more information on operating the drive in this mode. Refer to **Figure 9** for a diagram illustrating connection of the transducer to Control Terminals.

1.3.1 System Configuration = 2: Analog Constant Pressure with redundant sensors and up to two PSI Setpoints.

This configuration allows the use of two 4-20 mA transducers. The primary sensor is connected to the **I1+** and **I1-** Control Terminals, with the backup sensor connected to the **I2+** and **I2-** Control Terminals. If the primary sensor fails, the backup sensor will automatically take over control of constant pressure at the same settings.

- Up to two control setpoints can be used in this configuration. Enter the value of these set points in the Constant Pressure parameter, **1.4.1 PSI SETPOINT 1** – **1.4.2 PSI SETPOINT 2**. The table below shows what setpoint the system will follow based on the configuration of **AUX3**.
***AUX1 and AUX2 must also be closed for the system to run.**

Table 26 – System Configuration 2 Setpoints

AUX3	Active Sensor	Control Terminals	Operation
Off	Sensor 1 = PSI Setpoint 1	I1+, I1-	Primary sensor used for control
On	Sensor 2 = PSI Setpoint 2	I2+, I2-	Redundant sensor used for control

1.3.1 System Configuration = 3: Speed Reference I1.

Use this setting for motor speed control by an external 4-20 mA source connected to the I1 Control Terminals. Refer to **Figure 9** for a diagram illustrating connection of the transducer to Control Terminals. The drive will ignore the analog signal until it reaches a value proportional to the speed set by the parameter, **1.1.1 MIN FREQUENCY**, which has a factory default setting of 30 Hz. For speed control across the full-scale range of the analog signal, set **1.1.1 MIN FREQUENCY** to the minimum value of 5 Hz. AUX1 and AUX2 must be closed to run in this System Configuration.

1.3.1 System Configuration = 4: Speed Reference I2.

Use this setting for motor speed control by an external 4-20 mA source connected to the I2 Control Terminals. Refer to **Figure 9** for a diagram illustrating connection of the transducer to Control Terminals, but use I2 terminals instead of I1. The drive will ignore the analog signal until it reaches a value proportional to the speed set by the parameter, **1.1.1 MIN FREQUENCY**, which has a factory default setting of 30 Hz. For speed control across the full-scale range of the analog signal, set **1.1.1 MIN FREQUENCY** to the minimum value of 5 Hz. AUX1 and AUX2 must be closed to run in this System Configuration.

1.3.1 System Configuration = 5: Speed Pot Control.

Use this setting for motor speed control by a potentiometer or an external 0-10 VDC source connected to the 0-10 VDC Control Terminals. Refer to **Figure 10** for a diagram illustrating connection of the potentiometer or the voltage source to Control Terminals. The drive will ignore the DC analog signal until it reaches a value proportional to the speed set by the parameter, **1.1.1 MIN FREQUENCY**, which has a factory default setting of 30 Hz. For speed control across the full-scale range of the analog signal, set **1.1.1 MIN FREQUENCY** to the minimum value of 5 Hz. AUX1 and AUX2 must be closed to run in this System Configuration.

1.3.1 System Configuration = 6: Analog Constant Pressure with HOA and Speed Potentiometer.

This setting allows the user to either turn the motor off, control motor speed with a potentiometer, or operate in analog constant pressure mode using an HOA switch. Access to the keypad is not required to operate in this mode. A mechanical HOA switch changes the state of AUX1 and AUX3 Control Terminals to change to mode of operation in this configuration. A potentiometer is connected to the 0-10 VDC control Terminals, a 4-20 mA analog transducer is connected to the I+ and I- Control Terminals, and a double pole, triple throw HOA switch is connected to AUX1 and AUX3 Control Terminals.

The AUX1 control determines the motor's run and stop functions: when the switch is in the **OFF** position, AUX1 is open, and the motor will stop; when in either **HAND** or **AUTO** position, AUX1 is closed, allowing the motor to run. AUX3 toggles between operation modes: in **AUTO** position with

AUX3 open, the drive operates in an analog constant pressure mode; in **HAND** position with AUX3 closed, the potentiometer controls the motor speed. This configuration enables external control of motor operation and mode selection without requiring keypad access, providing a versatile and straightforward control setup.

Table 27 – Function of VFD Based on HOA Switch Status

HOA Position	AUX 1	AUX3	Function
Off	Off	N/A	Motor Stopped
Auto	On	Off	Analog Constant Pressure
Hand	On	On	Speed control

Refer to **Figure 9** for a diagram illustrating connection of the transducer to Control Terminals. AUX2 must be closed to run in the Analog CP Mode (Auto), and AUX 2.

1.3.1 System Configuration = 7: Analog Constant Pressure Swap Sensors.

This configuration supports the use of two 4–20 mA transducers. The primary sensor is connected to the **I1+** and **I1-** control terminals, while the backup sensor is connected to the **I2+** and **I2-** terminals. If the primary sensor fails, the drive will automatically switch to the backup sensor, maintaining constant pressure at the same settings. Additionally, the active sensor can be determined based on the state of **AUX3**, as illustrated in the table below.

Table 28 – Primary Sensor Based on AUX3 Status

AUX3	Active Sensor	Control Terminals	Operation
Off	Primary Sensor	I1+, I1-	Primary sensor used for control
On	Backup Sensor	I2+, I2-	Backup sensor used for control

***Note:** When AUX3 is **Off**, the primary sensor controls the system; when AUX3 is **On**, the backup sensor takes control. A two-way selector switch can also be used to toggle AUX3.

1.3.1 System Configuration = 8: HOA Speed Reference Selector.

This configuration allows multiple speed references to be used. The table below shows how AUX3 determines which analog input to use for setpoint control. AUX1 must be closed for the system to run.

Table 29 – Speed Reference Based on AUX3 Status

HOA Position	AUX 1	AUX3	Function
Off	Off	N/A	Motor Stopped
Auto	On	Off	I1 4-20 mA Speed Reference
Hand	On	On	0-10 VDC Speed Reference

1.3.1 System Configuration = 9: Pump Down Open Loop.

This configuration determines pump speed based on fluid level as measured by a 0-10 VDC or 4-20 mA transducer. **As the fluid level rises the system will operate at an increasingly higher frequency.*

1.3.1 System Configuration = 10: Modbus with HOA and Speed Pot.

This setting allows the user to either turn the motor off, control motor speed with a potentiometer, or operate in analog constant pressure mode using an HOA switch.

Table 30 – Function of VFD Based on HOA Switch Status

HOA Position	AUX 1	AUX3	Function
Off	Off	N/A	Motor Stopped
Auto	On	Off	Modbus control
Hand	On	On	Speed control

7.6 Start-Up and Shut-Down Ramp Times

Start-up and shut-down ramp times define the duration required for the drive to transition from Minimum Frequency to Maximum Frequency (and vice versa) when operating in System Configurations 0 and 4. These ramp profiles are adjustable via the Operating Parameters menu using the keypad and text display. The default factory setting for **1.1.3.1 STARTUP RAMP TIME** is 12 seconds, while **1.1.4.1 SHUTDOWN RAMP TIME** is disabled by default, due to the **1.1.11 COAST TO STOP** setting being set to **NO**.

⚠ Caution: *Submersible motors have limited tolerance to extended shutdown ramp times; caution should be exercised when adjusting this parameter to prevent potential damage.*

- **SUBMERSIBLE PUMP Parameter and Minimum Frequency**

When set to **YES**, the parameter **1.1.13 SUBMERSIBLE PUMP** limits the time to accelerate from 0 to the minimum frequency to within one second, providing protection for the thrust bearing in the motor. In any system configuration utilizing analog control, the drive will then use **1.7.1 ACCELERATION TIME** to define the ramp profile. For detailed instructions, refer to **Section 5.1**.

When **1.1.13 SUBMERSIBLE PUMP** is set to **NO** in an analog control system, the motor will default to the 12-second ramp time specified in **1.7.1 ACCELERATION TIME** to ramp from minimum to maximum frequency.

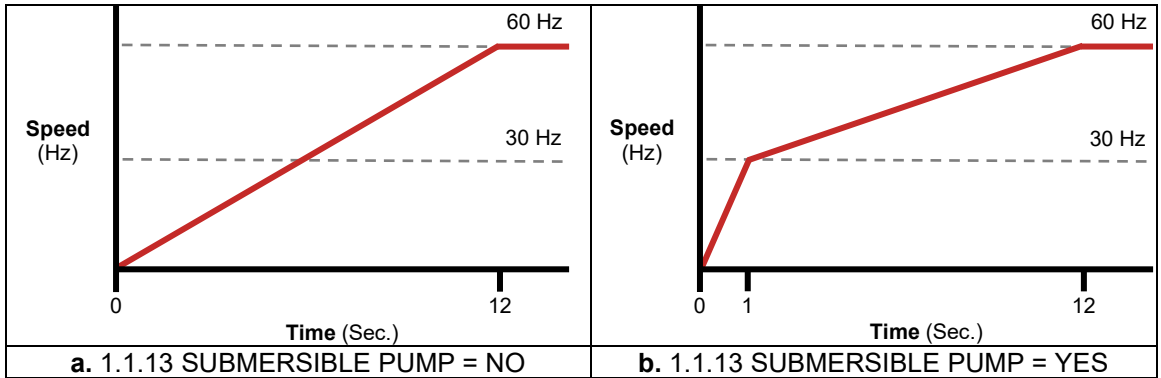

Figure 14 - Ramp Profiles for 1.1.13 SUBMERSIBLE PUMP

7.7 Motor Control Methods (V/f vs. Torque Control)

Advanced motor control methods can be selected through Operating Parameters found in **Table 25**.

V/f Controls

- V/f control (Voltage-to-Frequency control) is a fundamental method used in variable frequency drives (VFDs) to regulate the speed of an AC motor. It involves maintaining a constant ratio between the motor supply voltage and the frequency supplied by the drive. By adjusting both voltage and frequency proportionally, the drive controls the motor's speed while ensuring sufficient torque.
- V/f Control is a simple method that maintains a constant voltage-to-frequency ratio for basic speed regulation, suitable for applications like fans and pumps. Open-Loop Vector Control uses mathematical models to estimate rotor position, allowing precise control of torque and speed, especially at low speeds, making it ideal for high-performance applications. While V/f control is straightforward and cost-effective, open-loop vector control offers better dynamic performance but is more complex.
- The simplicity of V/f control results in speed regulation of approximately 2-3% of maximum frequency, whereas open-loop vector control achieves about 0.2%. This level of speed accuracy with V/f control is sufficient for most standard applications.

Torque Control

- Torque control in a VFD (Variable Frequency Drive) is a mode of operation where the drive directly regulates the motor's torque output. Instead of focusing primarily on maintaining a certain speed, the drive adjusts voltage and frequency to keep the motor producing a specified torque level, regardless of load variations. Provides consistent torque output, ensuring the load receives a steady force or power regardless of changes in speed or load conditions. It can be implemented with both V/f or Open-Loop Vector Control.

Note: It is important that accurate motor information is provided to the drive for open loop vector control. Be sure to enter the motor nameplate values for the parameters **1.8.2 Motor Rated Voltage**, **1.8.3 Motor Rated Current** and **1.8.4 Motor Rated RPM** when this mode is selected.

1.7.12 Torque Limit

- **Torque limit** in a VFD sets the maximum torque the drive can deliver to protect the motor and equipment from overload. When the commanded torque reaches this preset value, the drive reduces output to stay within safe limits, ensuring safe and reliable operation. This parameter is applicable for both motoring mode (positive torque) and regenerative mode (negative torque). The drive will reduce motor speed to avoid exceeding the torque limit.

1.7.13 Flux Reference

- Torque is equal to flux times current. Flux reference to the motor is automatically calculated by the inverter using the motor parameters. Users can adjust the flux reference from 10% to 200% of the calculated flux reference. This parameter might be used when the drive experiences overcurrent trying to start a heavy load. At light loads, using the rated flux values decreases the efficiency of the drive. By using flux optimization, the efficiency of the drive increases when operating below rated load.
- Flux reference can greatly affect the performance of the system. A flux reference that is too low results in smaller torque production in the motor with large stator currents. If flux reference is too high, the result is high ripple in torque, large stator currents and low efficiency. Caution should be exercised when adjusting this parameter. Make changes in small increments and monitor motor performance.

8 Constant Pressure Control & Perfect Pressure

A constant pressure system automatically modulates the pump speed to ensure that system pressure remains steady, improving efficiency and reducing energy consumption compared to traditional on/off pump control methods.

8.1 Control Principles of Constant Pressure Systems

- The control principles of a constant pressure system in a VFD are based on real-time feedback and dynamic adjustment of the pump's speed to maintain a steady system pressure. The key principles include:
 - **Pressure Feedback:** A pressure sensor or transducer continuously monitors the system pressure and sends this data to the VFD.
 - **Setpoint Comparison:** The drive compares the real-time pressure reading to a predefined pressure setpoint programmed into the system.
 - **PID Control (or similar algorithms):** The VFD uses a control algorithm (often PID) to determine the necessary speed adjustment based on the difference between actual pressure and setpoint.
 - **Adjusting Pump Speed:** The drive modulates the motor speed by varying the output frequency and voltage, increasing speed if pressure drops below setpoint, or decreasing speed if pressure exceeds setpoint.
 - **Maintaining Consistency:** This continuous feedback and adjustment loop ensures the system maintains a stable pressure despite changes in demand or flow conditions.
- Three basic conditions must be met for the pump to shut down and enter sleep mode:
 1. The value (PSI, GPM, FT) in the system must be at the value control point set by the parameter **1.4.1 ANALOG SETPOINT 1** or at the value determined by the setting on the analog sensor.
 2. The frequency is below **1.4.5 SLEEP FREQUENCY** (as defined as **1.1.1 MIN FREQUENCY** + input value) or measured value is above **1.4.6 FORCE SLEEP THRESHOLD** (defined as **1.4.1 ANALOG SETPOINT 1** + the input value).
 3. The time expired since the pump started after the last OFF cycle must be greater than parameter **1.4.23 T1 ON** or **1.4.24 T2 ON**.

8.2 Preventing Short Cycling

Short cycling is primarily caused by overly sensitive control settings, sensor noise, rapid demand fluctuations, or poor system design. Below are parameters that can help prevent short cycling in constant pressure systems.

- **Sleep Mode Parameters:**

Enable and configure sleep mode parameters (such as **Sleep Frequency**, **Force Sleep Threshold**, and **Wake Up Threshold**) so the drive turns the pump off when flow or pressure is below a certain level, then back on only when conditions exceed the wake-up threshold. This reduces unnecessary on/off cycling. These settings can be found under **1.4 CONSTANT PRESSURE PARAMETERS**.

- **Acceleration/Deceleration Ramp Time:**

Using Acceleration/Deceleration Ramp Times from **1.7 PID CONTROL PARAMETERS** can add to the run time of a system. However, this delay can cause pressure to drop as the motor ramps up.

8.3 Adjusting Auto Sleep Settings

- **1.4.25 AUTO SLEEP BANDWIDTH** (*Default 1.5% of Setpoint*) defines a pressure deadband around the setpoint, ensuring the system only responds when pressure or flow deviates significantly from the target. Expressed as a percentage of the setpoint, the drive will not initiate sleep mode unless it can reduce the frequency and maintain system pressure within this bandwidth. This helps prevent frequent on/off cycling due to low flow, improving system stability and efficiency.
- **1.4.26 AUTO SLEEP DETECTION TIME** (*Default = 3 Seconds*) defines the length of time the analog measurement (psi/flow) remain within the auto sleep bandwidth range before auto sleep can be activated.
- **1.4.27 AUTO SLEEP CURVE** (*Default = 18*) sets how quickly frequency falls once auto sleep has been activated due to the psi/flow staying within the auto sleep bandwidth for the time set by auto sleep detection time.

Auto Sleep Example Using Default Parameters: With a setpoint of 50psi programmed by the user the operating psi must stay within +/- 1.5% of 50psi for 3 seconds before frequency is reduced at the rate determined by the auto sleep curve. If, during frequency reduction, pressure falls outside of +/- 1.5% auto sleep is disabled and frequency will ramp to build pressure back to setpoint.

8.4 Adjusting PID Settings

- **1.7.3 INTEGRAL GAIN** ensures smooth, accurate control during low flow conditions by accumulating and compensating for small errors over time, maintaining consistent system performance without causing abrupt or frequent adjustments. Errors are simply the differences between the desired target, say a 50psi setpoint, and the actual measurements. Example: Setpoint = 50psi but the system is overshooting to 54psi. Error = 4
- **1.7.4 PROPORTIONAL GAIN** helps smooth the system's response, providing a balanced control effort that minimizes unnecessary cycling by reacting proportionally to deviations, thus improving stability during low flow or pressure conditions.

Note: **Proportional gain provides immediate, proportional correction, while **integral gain** corrects accumulated past errors to eliminate long-term deviations.*

- **1.7.5 DERIVATIVE GAIN** can help prevent short cycling by correcting overshoot that may be prematurely putting the drive to sleep. If the system is approaching the setpoint quickly, derivative action reduces the control effort to prevent overshoot and rapid on/off switching.
- **1.7.12 PID UPDATE RATE** and **1.7.13 PID MEASUREMENT FILTER RATE** can both help prevent overshoot by ensuring the control system responds gradually and accurately. The update rate controls how often the system recalculates, while the measurement filter rate ensures the inputs are stable, together promoting a smoother, more stable response.

**Note: PID Control Parameters are the control of errors that allow your system to turn off and on while giving the user the impression that pressure/flow are constant. Changes to these parameters should always be made in small increments or the system may become unstable.*

⚠ CAUTION: Long ramp times can interfere with PI control of constant pressure. It is advisable to start with factory default ramp times.

8.5 Adjusting ON/OFF Cycle Timers

- These timers control the minimum time between pump start and stop events to prevent rapid cycling, protecting equipment and ensuring stable operation.
- The control system records the duration of each OFF cycle and compares it to the parameter **1.4.23 T OFF**. If the previous OFF period was longer than the value of **1.4.23 T OFF**, then the minimum ON time for the motor will be set to **1.4.23 T1 ON**. Conversely, if the OFF time was shorter than **1.4.23 T OFF**, the minimum ON time will be set to **1.4.24 T2 ON**.
- In essence, the length of the last OFF cycle determines whether the subsequent ON cycle will be relatively long or short. **Figure 15** illustrates how the system dynamically adjusts the motor-on time based on the duration of the previous OFF cycle.

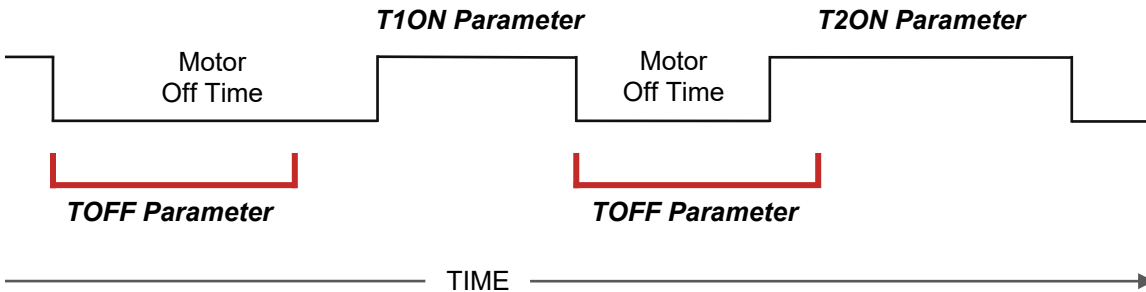

Figure 15 – Motor On and Motor Off Times

8.6 Adjusting Allowable Starts by Time

1.2.12 STARTUPS PER CYCLE and **1.2.13 MAX CYCLE TIME** can be used to prevent the system from short cycling due to a change in pump performance, waterlogged tank, or a change in application/design. Collectively, these parameters allow the user to set the acceptable amount of starts within a given time frame. An example would be 10 startups per cycle over a 10-minute cycle time. If the system is started in excess of the allowable limits a timer will appear on the LCD counting down the remaining time until a new startup is acceptable.

8.7 Emergency Over-Pressure Limit Switch

CP systems have the option of connecting an emergency over-pressure limit switch to the AUX2/COM terminals in case the main pressure control system fails. The emergency over-pressure setpoint should be at least 10 psi higher than the system control pressure to prevent nuisance tripping.

⚠ CAUTION: Long ramp times can interfere with PI control of constant pressure. It is advisable to start with factory default ramp times.

Pressure Control at Minimum Speed

There is a potential conflict between the minimum pump speed setting, controlled by parameter **1.1.1 MIN FREQUENCY**, and the pressure setpoint of the transducer. Specifically, if under no-flow conditions the pump operating at its minimum speed produces a pressure higher than the desired setpoint, adjustments may be necessary. Since reducing the minimum speed is generally not an option with submersible pumps, the alternative is to increase the pressure setpoint. In most cases, pumps operating at around 30Hz should not generate enough pressure head to cause this issue.

8.8 PerfectPressure™ Setup – Analog Constant Pressure

- Upon initial startup, or, after restoring factory defaults (using the Two Button Reset Procedure on page 31), the drive will prompt you to quickly set up a constant pressure system. The display will read:
 - **RUN CONSTANT PRESSURE WIZARD? YES(ENTER)/NO(BACK)**
 - Press **ENTER** to proceed with the setup, or **HOME** to decline. This allows you to configure basic parameters for analog constant pressure operation without navigating through all menu options.

Follow this procedure to set up PerfectPressure:

1. Press **ENTER** to proceed with the wizard.
2. **1.4.38.1 MAX ANALOG PSI SENSOR RANGE**
Sets the range of the 4–20 mA pressure sensor. Default = 150.00
3. **1.4.1 ANALOG SETPOINT 1** – This value determines the pressure you want to maintain. The factory default is 50 psi. Use the arrow keys to change if desired. Press **ENTER** to proceed.
4. **1.1.13 SUBMERSIBLE PUMP** – This parameter sets the ramp profile for a submersible pump. **YES:** Submersible pump (*frequency accelerates from 0–30 Hz within 1 second, then ramps to max frequency*).
NO: Vertical pump (*frequency increases linearly from 0 to max*).
Note: For submersible pumps, reaching 30 Hz within 1 second is critical to protect the pump.
5. **DISABLE MANUAL MODE**
6. **Manual Mode** allows direct, local control of the drive and motor, bypassing automated or remote commands, useful for testing, setup, or emergency situations.
Note: *Since manual mode bypasses all controls, operation in a closed system will likely cause an overpressure event.*
7. **1.1.9 OVERCURRENT LIMIT** – Parameter setting that defines the maximum allowable current the drive will permit to flow to the motor.

The system will now initialize in the **OFF** position, indicated in the top left corner of the LCD screen where the run status is displayed. To begin operation, press the green **RUN/AUTO** button. It is recommended to review the entire section on **constant pressure control** for a comprehensive understanding of the control methods. For advanced tuning and additional menu options, refer to **Table 22** to fine-tune your constant pressure system.

8.9 Analog Constant Pressure Systems

- The analog constant pressure (CP) system utilizes an analog pressure transducer connected to the drive's control terminals (see Figure 16 for wiring details).
- Some systems may require tuning the PID Loop. In such systems, a proportional-integral (PI) or proportional-integral-derivative (PID) controller is typically used within the feedback loop to optimize performance. This controller has a gain adjustment that must be tuned by the user for each application to achieve the best balance between stability and responsiveness.
 - In PI control mode, the pressure transducer's analog signal is compared to the parameter **1.4.1 ANALOG SETPOINT 1**, which determines the pressure the system aims to maintain. The difference (error) between the transducer signal and the setpoint is multiplied by the **1.7.4 PROPORTIONAL GAIN**. This resultant signal dictates the motor frequency needed to maintain the desired pressure. If the pressure matches the setpoint, the motor speed would be zero; increasing the proportional gain and integral gain reduces the pressure error but can also make the system more prone to oscillations.
- Additional adjustable parameters within the constant pressure menu allow further optimization of the system's performance. The drive is shipped with default settings suitable for many applications, but tuning these parameters can help balance tight setpoint control, motor efficiency, and system stability. As always, tradeoffs exist between precision, efficiency, and stability, and these should be considered during system setup.

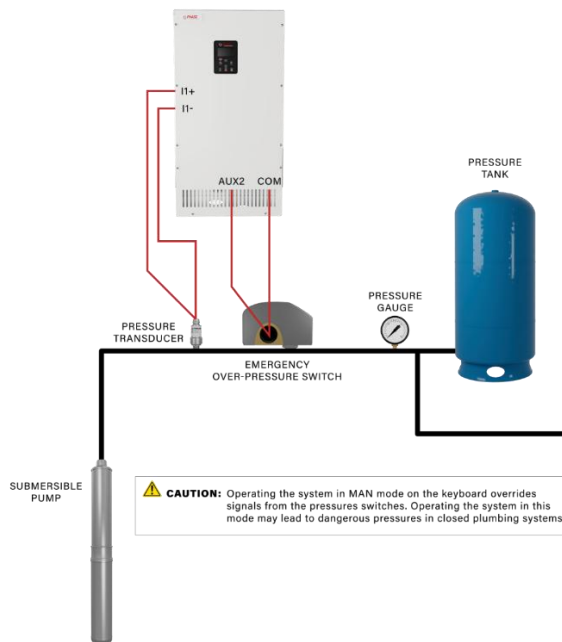

Figure 16 – Analog Constant Pressure One-Line Diagram

Wiring – Digital Over-Pressure Switch:

Overpressure Sensor:

- Plumb the over-pressure switch into the water line at the designated location (Figure 16).
- Connect a twisted pair of wires from the switch's normally closed (NC) and common (COM) terminals to the corresponding AUX2 and COM terminals on the VFD. Ensure that the setting is at least +10psi greater than setpoint.

**Note: 1.4.6 FORCED SLEEP THRESHOLD (PSI) by default is programmed to +20psi of setpoint.*

Wiring – Analog Pressure Transducer

- Navigate through the keypad to **1.3.1 SYSTEM CONFIG**. Select **2** to set the system configuration for an analog CP system (see **Table 22** for details).
- Attach the cable shield to the Control Terminal Ground post located in the drive enclosure adjacent to the Control Terminals.
- Connect the positive terminal of the transducer to the I1+ Control Terminal, and the negative terminal to the I1- Control Terminal. **Note: Only allow approximately 2” of unshielded cable.*
- If a redundant analog transducer is used, connect it to the I2+ and I2- Terminals in likewise fashion. See **Section 7.5** for instructions on using an additional analog sensor.
- Set the **1.4.1 ANALOG SETPOINT 1** on the keypad (see **Table 22** for details)
- Set the keypad to AUTO mode to operate the system.

⚠ CAUTION: *The use of shielded cable is recommended. Regular wire may induce capacitance in the line and corrupt the signals from the pressure switches.*

8.10 Pre-Charge Mode

- When filling a large plumbing system with water, it is often beneficial to fill the system slowly to prevent water hammer damage—such as sprinkler head blow-off or pipe bursts—when the system reaches full pressure.
- In analog constant pressure (CP) systems, a low-flow pre-charge can be implemented before the pump reaches full speed. This feature is disabled if the **1.4.10 PRECHARGE TIME** parameter is set to zero. During the pre-charge interval, the pump frequency will not exceed the value specified by **1.4.9 PRECHARGE FREQUENCY**.
- For both types of CP systems, the pre-charge interval can also terminate early if the system pressure exceeds the value set by **1.4.11 PRECHARGE PSI**. In this case, **1.4.11 PRECHARGE PSI** must be lower than the **1.4.1 ANALOG SETPOINT 1**.
- In either system, the pre-charge process occurs automatically whenever the drive is switched from OFF to **AUTO** or **MANUAL** → **RUN** mode.

Pre-charge Mode Setup:

1. Using the keypad menu, navigate to **1.4.9 PRECHARGE FREQUENCY** and enter the desired pre-charge frequency.
2. Navigate to **1.4.10 PRECHARGE TIME** and input the pre-charge duration in seconds.
3. For analog constant pressure systems only, go to **1.4.11 PRECHARGE PSI** and enter the pre-charge pressure in psi. Ensure this value is lower than **1.4.1 ANALOG SETPOINT 1**.
4. Finally, set the keypad to **AUTO** mode to activate system operation.

8.11 Lead/Lag Pump Control

- Lead/lag control in pumping systems is a common approach to maintain pressure amid highly variable flow demands. Typically, the system consists of a master pump controlled by a VFD operating in constant pressure mode, along with auxiliary pumps that are controlled by the drive.
- When the master pump cannot sustain the system pressure, it activates an auxiliary pump by closing a relay on the control terminals. Alpha Drives can manage up to three auxiliary pumps, with features designed to minimize oscillations and ensure smooth staging and destaging of pumps.
- In any analog constant pressure system configuration, the **Lead/Lag** control menu becomes available. Refer to **Table 23** for available lead/lag control options. Up to three additional pumps can be controlled via programmable relays on the main control PCB. When the parameter **1.5.1 NUMBER LAG PUMPS** is set above zero, these relays switch to control lead/lag operation for constant pressure. *Additionally, up to four more pumps can be managed over Modbus using lead/lag control.*

⚠ CAUTION: Activation of lead/lag control overrides the function of all programmable relays. Any function of these relays set up through the Interface Parameters (**Table 21**) will be disabled.

Lead/Lag Set-up and Operation

- To enable lead/lag control, the system must be configured in a constant pressure mode (see Section 6.5). Set the number of lag pumps greater than zero in parameter **1.5.1 NUMBER LAG PUMPS**. Programming involves:
 - Navigating to **1.5.1** and setting the desired number of auxiliary (lag) pumps.
 - Adjusting other lead/lag parameters as needed, based on system requirements.
 - Lag pumps are controlled via programmable relays connected through the control terminals. The drive stages in auxiliary pumps starting with Relay 1, in sequence, to maintain system pressure efficiently and smoothly, mitigating pressure oscillations, short cycling, and water hammer. **Figure 18** provides a wiring diagram.

Staging and Destaging Logic:

- Pump Staging (In):
 - The system pressure drops to **1.4.1 ANALOG SETPOINT 1** minus **1.5.15 STAGE ANALOG LAG** (e.g., 50 psi setpoint minus 5 psi lag = 45 psi), and after a delay **1.5.2** expires, the drive stages in a lag pump by closing a relay.
 - During staging, the master pump speed increases to **1.1.1 MIN FREQUENCY + 1.5.11 DESTAGE FREQUENCY BOOST** (e.g., 30 Hz + 5 Hz = 35 Hz) for **1.5.5 DESTAGE TIME**, then resumes normal control.
 - Sequence Overview:
 1. Relay opens to activate (stage) the lag pump.
 2. The master pump speed increases to **1.1.1 MIN FREQUENCY + 1.5.11 DESTAGE FREQUENCY BOOST** (e.g., 30 Hz + 5 Hz = 35 Hz).
 3. The master pump runs at this increased speed for **1.5.5 DESTAGE TIME**.
 4. After this period, normal constant pressure control resumes.

- **Pump Destaging (Out):**
 - When the pressure rises to **1.4.1 ANALOG SETPOINT 1 + 1.5.16 DESTAGE ANALOG LAG** (e.g., 500 GPM + 50 GPM = 550 GPM), and after delay **1.5.3** expires, the drive will destage the lag pump.
 - During destaging, the drive boosts the master pump frequency to **1.1.1 MIN FREQUENCY + 1.5.6 DESTAGE MIN FREQUENCY** (e.g., 30 Hz + 5 Hz = 35 Hz), allowing the PI loop to react faster to pressure changes.
 - Sequence Overview:
 1. The system measurement increases by **1.5.11 DESTAGE FREQUENCY BOOST** (e.g., 5 Hz), providing extra motor power for faster PI response.
 2. The drive destages the auxiliary pump.
 3. The boost in motor power continues for **1.5.5 DESTAGE TIME**.
 4. Normal constant pressure control resumes.

This staged approach ensures efficient pump operation, minimizes pressure fluctuations, and extends equipment life through smooth, controlled staging and destaging based on system demand. See Lead/Lag Parameters from Table 23.

8.12 Duplex / Multiplex Control

- Duplex Control is simple, mainly for redundancy and basic lead/lag switching between two systems. Also known as alternating lead/lag.
- The purpose of a multiplex system is to rotate the use of multiple VFD's so that a single drive or pump does not degrade at a faster rate than others in the system. The first pump to be staged in, and the last pump to be destaged, is called the Primary VFD. The Primary VFD will decide when to stage or destage the other VFDs. Multiplex Control involves advanced communication and sequencing, managing multiple systems for optimal efficiency, load sharing, and system resilience.
- **Set-Up and Operation:**
 - **Constant Pressure Operation:**
Both the Primary and Secondary VFDs operate in constant pressure mode. If the Primary detects that pressure cannot be maintained, it issues a run command to a Secondary VFD to bring additional capacity online.
 - **Control Methods:**
Multiplex control can be achieved via modbus communication or programmable relays on the Primary VFD. **1.3.1 SYSTEM CONFIGURATION** must be set for constant pressure AND **1.3.2 MENU COMPLEXITY** has been set to standard or advanced. See section 6.4 & 6.5.
 - **Modbus:** Supports up to 5 auxiliary VFDs.
 - **Relays & Digital Inputs:** Supports up to 3 auxiliary VFDs.
 - **Staging and Destaging Logic:** See section 7.4 Staging and Destaging Logic
 - The sequence of staging/destaging depends on which VFD is designated as the Primary.
 - When the Master VFD is not the Primary, it will always be staged in second.
 - The Primary drive position rotates based on **1.4.41 DUPLEX CYCLE TIME**, ensuring even wear among all pumps over time.

Table 31 – Duplex/Multiplex Rotation Sequence

Master + 1 Slave VFD		
Rotation	Primary Drive	VFD Order
1 st Rotation	Master	M <=> 1
2 nd Rotation	Slave VFD 1	1 <=> M

Master + 2 Slave VFD		
Rotation	Primary Drive	VFD Order
1 st Rotation	Master	M <=> 1 <=> 2
2 nd Rotation	Slave VFD 1	1 <=> M <=> 2
3 rd Rotation	Slave VFD 2	2 <=> M <=> 1

Master + 3 Slave VFD		
Rotation	Primary Drive	VFD Order
1 st Rotation	Master	M <=> 1 <=> 2 <=> 3
2 nd Rotation	Slave VFD 1	1 <=> M <=> 2 <=> 3
3 rd Rotation	Slave VFD 2	2 <=> M <=> 3 <=> 1
4 th Rotation	Slave VFD 3	3 <=> M <=> 1 <=> 2

Master + 4 Slave VFD		
Rotation	Primary Drive	VFD Order
1 st Rotation	Master	M <=> 1 <=> 2 <=> 3 <=> 4
2 nd Rotation	Slave VFD 1	1 <=> M <=> 2 <=> 3 <=> 4
3 rd Rotation	Slave VFD 2	2 <=> M <=> 3 <=> 4 <=> 1
4 th Rotation	Slave VFD 3	3 <=> M <=> 4 <=> 1 <=> 2
5 th Rotation	Slave VFD 4	4 <=> M <=> 1 <=> 2 <=> 3

Note: Setting 1.3.4 PROGRAM RELAY 1 to 6: JOCKEY PUMP, will cause Relay 1 to not participate in lead/lag or multiplex control. The order pumps are staged or destaged will remain the same, except the Master will skip Relay 1. Relay 1 will also never become the Primary when it is set to Jockey Pump.

Multiplex Modbus Wiring via RS-232

- To enable multiplex communication over Modbus, each drive must be wired in a two-wire RS-232 configuration before power is applied:
 1. **Configure the Control Board:**
 - Locate the **S1 switch** on the drive's control board (refer to **Figure 17**).
 - Turn **ON** both switches labeled “2WEN-” and “2WEN+” (switch position to the right).
 - Repeat this step for the **Primary** drive and all **secondary** VFDs designated for multiplex operation.
 2. **Wiring the Drives:**
 - Connect **RX+** on the **Primary** drive to **RX+** on all **secondary** drives.

- Connect **RX-** on the **Primary** to **RX-** on all **secondary** drives.

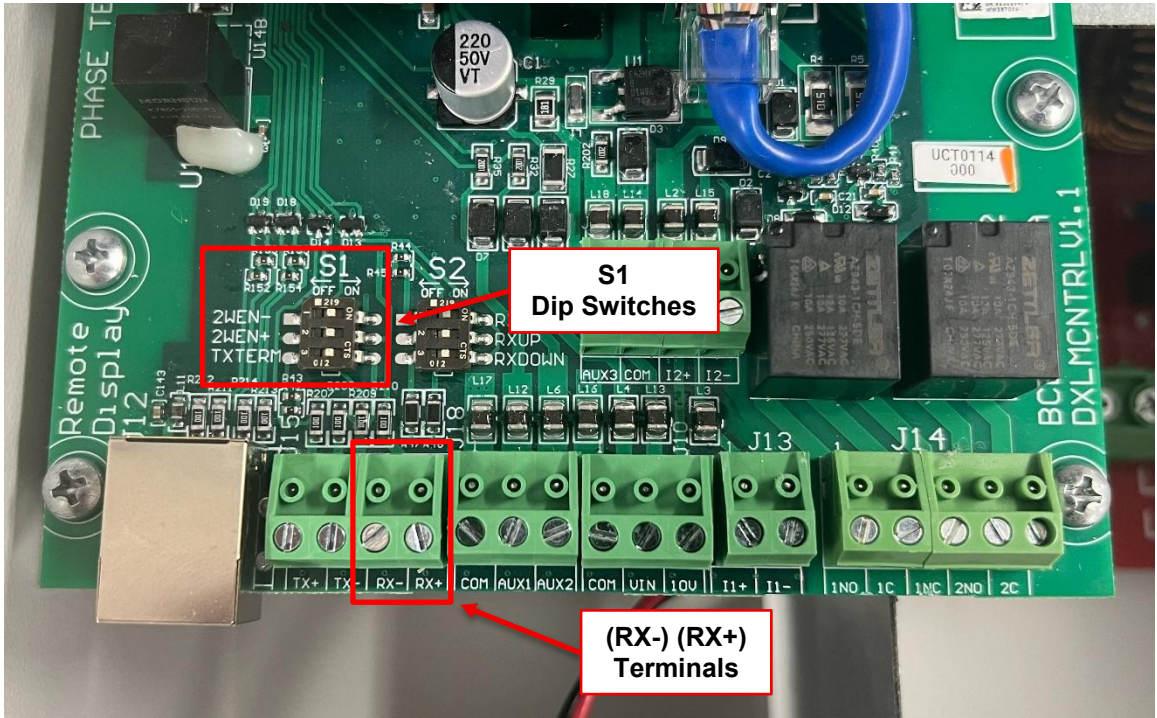

Figure 17 – Control Board Wiring Modbus

Multiplex Modbus Setup

- After all Multiplex drives are wired together, each drive will need to be programmed for Constant Pressure using the Constant Pressure Setup Wizard. If the drives are being initialized for the first time, this wizard will automatically show up on the display. If not, press and hold BACK and ENTER buttons for three seconds, then when the drive asks if you want to reset it to factory defaults, press ENTER for yes. After resetting, the drive display will now initialize on the Constant Pressure Setup Wizard.
- After programming each drive for Constant Pressure control, each drive will need to be programmed for Multiplex control.

Primary VFD Setup

1. On the Primary drive, navigate to **1.3.2 MENU COMPLEXITY** and press ENTER. Change this setting to **ADVANCED** and press ENTER to save the parameter.
2. Next, navigate to **1.6.1 MULTIPLEX SETUP** and press ENTER.
3. Set **MULTIPLEX TYPE** to **MODBUS** and press ENTER.
4. Set **MULTIPLEX ID & DEFAULT ROLE** to **“1 – PRIMARY”** and press ENTER.

5. Set **MULTIPLEX CYCLE TIME** to the amount of time each pump should run before cycling to the next pump. (This value represents clock time, not pump run time.) Press ENTER to save.
6. **SHARE TRANSDUCER MEASUREMENT** can be set to YES or NO, depending on the stem needs. If each VFD will use its own transducer, select NO. If only one transducer will be used, it can be installed in any of the VFDs and the value should be set to YES. Press ENTER to save.
7. After completing the previous step, the screen will display, "Multiplex Setup 1 – Setup all systems until the wait screen and press ENTER." Now move on to programming the secondary VFDs.

Secondary VFD Setup:

After the Primary VFD is programmed, use the following procedure to setup each secondary VFD.

1. Ensure each secondary VFD is programmed for Constant Pressure. If not, walk through the CP Setup Wizard.
2. Navigate to **1.3.2 MENU COMPLEXITY** and press ENTER. Change the value to ADVANCED and press ENTER to save the parameter. This unhides all menu items.
3. Next, navigate to **1.3.1 MULTIPLEX SETUP** and press ENTER.
4. Set **MULTIPLEX TYPE** to MODBUS and press ENTER.
5. Set **MULTIPLEX ID & DEFAULT ROLE** to "2 – Secondary" and press ENTER.
6. The screen will now display, "Multiplex Setup 1 – Waiting for Primary System."
7. If multiple secondary VFDs will be used, repeat the steps above for all, choosing the subsequent number for **MULTIPLEX ID & DEFAULT ROLE** for each (ie 3 – Secondary, then 4 – Secondary, etc).

Completing Multiplex Setup:

1. After completing these steps on all Multiplex VFDs, return to the Primary VFD and press ENTER.
2. The Primary screen will say "Found S2" with numbering matching the chosen Multiplex ID's for secondary units. Press ENTER to confirm or UP to retry.
3. If all VFDs are communicating properly, the Primary will say "Programming Complete." Press the HOME button on all VFDs to return HOME.
4. Press the RUN/AUTO button on all VFDs to begin pumping.

Multiplex Digital I/O Wiring

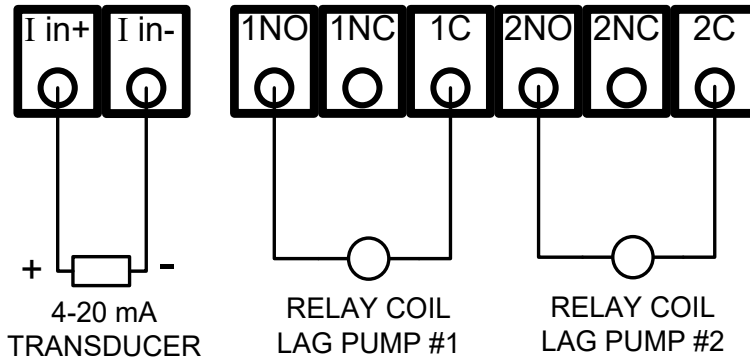

Use the relays in order, beginning with Relay 1.

CAUTION: The relays are rated 0-30 VDC or 120VAC, 0.5 amp. Direct control of the coil on a magnetic motor starter will likely cause damage to the relay and the main control printed circuit board. Use of a secondary control relay, such as an ice cube relay, may be necessary to control the lag pump motor starter.

Figure 18 – Connecting Duplex/Multiplex Systems

Multiplex Digital I/O Setup

- System configuration must be set to one of the constant pressure modes when using multiplex control. See **Section 7.5, System Configuration**, for details. Multiplex control is enabled when **1.5.1 NUMBER LAG PUMPS** is greater than 0, and **1.4.41 DUPLEX CYCLE TIME** is greater than 0.
- **Programming Steps:**
 1. Use the keypad to navigate to **1.5.1 NUMBER LAG PUMPS** and use the arrow keys to set the number of auxiliary drives in the system.
 2. Navigate to **1.4.41 DUPLEX CYCLE TIME**, use the arrow keys to set how often the default drive position will change.
 3. If necessary, adjust the remaining Lead/Lag parameters if operating conditions dictate.

8.13 De-Scale/De-Ragging (Pump Clean Out) Function

- The **De-Rag** function is designed to clear debris or blockages in pumps that may be causing flow restrictions. To enable and operate this function, ensure that:
 - **System Configuration (1.3.1)** is set to either **Constant Pressure** or **Pump Down** modes, so the **1.4 CONSTANT PRESSURE PARAMETERS** menu is accessible.
 - **Menu Complexity (1.3.2)** is set to **Advanced**.
- **To initiate the De-Rag function:**

- Navigate to **1.4.32 RUN DERAG** and press **ENTER**.
- You will be prompted to set the following parameters:
 - **Number of De-Rag Cycles**
 - **De-Rag Frequency**
 - **De-Rag Frequency Time**
- **1.4.33 DE-RAG SHORT CYCLE DELAY** controls how long the pump is off before starting again.

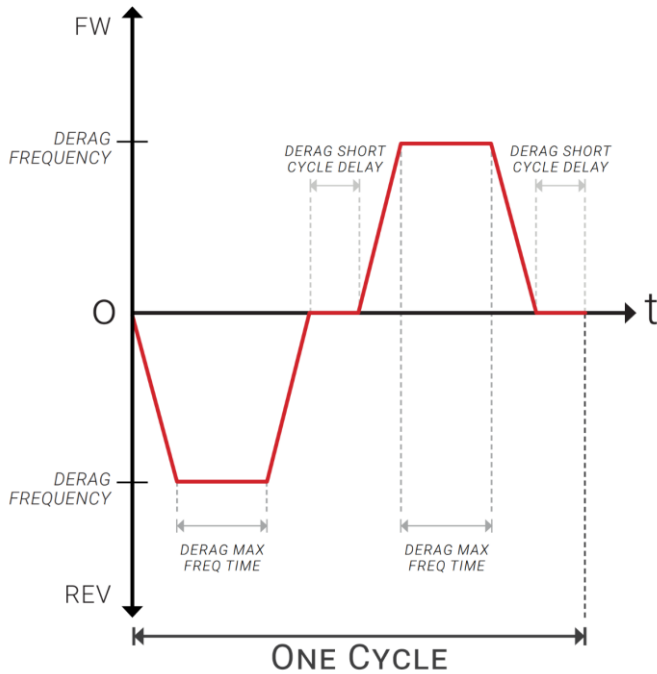

Figure 19 – Derag Function Diagram

9 Troubleshooting

This section provides information on fault codes and troubleshooting tips for potential system problems.

⚠ WARNING! *In some instances, the unit will shut down, then automatically restart when conditions allow. Always disconnect input power from the unit and wait for internal electrical charges to dissipate before performing service on the unit or its connected loads.*

⚠ WARNING: *Risk of electric shock. De-energize the unit by disconnecting all incoming sources of power, then wait for the time specified on the drive warning label, before servicing the equipment.*

⚡ HIGH VOLTAGE: *This equipment is connected to line voltages that can create a potentially hazardous situation. Electric shock could result in serious injury or death. This device should be installed and serviced only by trained, licensed, and qualified personnel. Follow instructions carefully and observe all warnings.*

Always check the display for fault codes if the drive or its load is not operating. Disconnecting the input power could potentially clear any fault code indication, possibly losing valuable information for troubleshooting.

9.1 Fault Codes

- Fault codes are indicated on the graphic display. See **Table 31** for a list of fault codes.
- The drive can be configured to automatically restart after certain faults, with an optional time delay before the restart occurs. To interrupt the countdown of a time delay and force an immediate auto restart, press and hold both arrow keys on the keypad for one second. The load will then start immediately. The **Restart Log** is a resettable fault log used to monitor faults that permit auto restart. You can use the **Clear Memory** function to reset the Restart Log and set all fault counters to zero.
- For detailed instructions on accessing the Restart Log and performing the Clear Memory operation, refer to **Section 4.2, Keypad Main Menu Items**.

⚠ WARNING: *Certain faults indicate potential damage to the drive or load, or represent hazardous conditions, and therefore prevent the drive from automatically restarting. When such faults occur, the display will read **NO AUTO RESTART**. To determine whether a specific fault allows an auto restart, refer to **Table 31, Fault Codes**; a "1" in the notes column indicates that auto restart is **not permitted** for that fault. In these cases, it is important to **contact the factory for assistance** before attempting to restart, or to thoroughly troubleshoot the system. To clear these faults, you can either cycle the input power **OFF** and then **ON**, or press **both arrow keys simultaneously for 3 seconds**.*

⚠ WARNING: *Unit may restart automatically without warning after a fault when operating conditions permit. Make certain input power is disconnected before servicing the unit or its connected loads.*

9.2 Clearing a Fault

- When the unit is programmed for automatic restart after a fault, the display will indicate that a restart is pending and show a countdown timer for the seconds remaining until the load restarts. This countdown can be interrupted at any time by pressing and holding both the UP and DOWN arrow keys, which will cause the load to restart immediately. By default, the number of auto restarts allowed after a fault is zero; to enable automatic restarts, you must program the desired

number of restarts and the delay time between faults and restarts under parameter **1.2.2, NUMBER OF AUTO RESTARTS**.

- If the drive exceeds the programmed number of auto restarts, or if auto restart is disabled, the display will show the fault on the top line. The second line will prompt **RESTART? ENTER**. Pressing **ENTER** will clear the fault and restart the load. This action also resets all fault counters in the **Restart Log** to zero. For more information, see **Section 4.6, Restart Log**.
- The parameter **1.2.1, ENABLE RESTART**, controls whether the drive can automatically restart after faults. When enabled, the drive will also initialize in **AUTO** mode after an input power cycle. The factory default setting permits auto restarts; refer to **Table 21** for details.
- Certain faults are considered critical and **do not** permit auto restart, as they could indicate potential damage or hazardous conditions. When such faults occur, the display will read **NO AUTO RESTART**. In these cases, **contact the factory** before attempting to restart, or thoroughly troubleshoot the system. These faults can only be cleared by cycling power **OFF** and **ON**, or by holding both arrow keys for **3 seconds**.
- Additionally, some faults may be indicated during drive energization or initialization but are **not** recorded in the fault log. These typically include transient conditions such as ground faults, pre-charge failures, or input voltage irregularities. If detected during startup, the drive will wait for the condition to clear before entering normal operation. If these conditions occur after startup, a fault will be logged and can be cleared normally.

⚠ WARNING: *The drive may start automatically without warning when operating conditions permit. Make certain input power is disconnected before servicing the unit or its connected loads.*

Table 31 – Fault Codes

MESSAGE	DESCRIPTION / COMMENTS	PARAM RELATED (1)	NO AUTO RESTARTS (2)
Alarm Fault	Triggered when an alarm occurs that has been set to Fault via the 11 ALARMS menu.	X	
AUX1 Latch Fault	Switch connected to AUX1 input has closed. Drive will remain off until fault is cleared. See parameter 1.3.8 AUX 1 SELECT .	X	X
AUX2 Latch Fault	Switch connected to AUX2 input has closed. Drive will remain off until fault is cleared. See parameter 1.3.19 AUX 2 SELECT .	X	X
AUX3 Latch Fault	Switch connected to AUX3 input has closed. Drive will remain off until fault is cleared. See parameter 1.3.10 AUX 3 SELECT .	X	X
Broken Pipe Fault	Indicates the possibility of a broken pipe. Fault is triggered when drive cannot reach the Analog Setpoint. Check parameter 1.4.16 BROKEN PIPE THRESHOLD to eliminate the possibility of nuisance fault.	X	
Bus Overvoltage	Sudden and severe regenerative power under high line voltage conditions may result in bus overvoltage. Check line voltage or consider increasing ramp up and ramp down times. Will trip if bus reaches 250 VDC on 115V systems or 450VDC on 230V systems.		
Bus Voltage Unbalance	The DC bus voltages are more than 10% unbalanced. Can be caused by bus cap failure.		

MESSAGE	DESCRIPTION / COMMENTS	PARAM RELATED (1)	NO AUTO RESTARTS (2)
Current Unbalance	Motor current unbalance has exceeded the 1.1.29 CURRENT UNBALANCE limit. Check motor load for normal operation. Fault can be bypassed by increasing parameter 1.1.29 CURRENT UNBALANCE .	X	
Ground Fault	A fault between an output line and earth has been detected. Immediately disconnect input power and check output lines with a megger to verify fault. The sensitivity of fault detection can be adjusted by the parameter 1.1.12 GROUND FAULT SENSITIVITY .	X	X
High Input Voltage	Input voltage has exceeded the following levels for 10 seconds: 160VAC for 115V systems, 260VAC for 230V systems. Reduce input voltage.		
Low Input Voltage	Input voltage has fallen below a level for safe operation of the drive. Will trip on startup if input voltage is below 90VAC for 115V systems or below 180VAC for 230V systems.		
Low Suction Fault	PSI measured below 1.4.40 LOW PRESSURE FAULT LEVEL for longer than specified 1.4.39 SUCTION PRESSURE TIME .	X	
Motor Overload	Output current has exceeded the value set by parameter 1.1.9 OVER CURRENT LIMIT . Check motor load. Ensure that 1.1.18 OVERCURRENT DERATE ENABLE is set to YES.	X	
OP Hall Sense Hi	Current exceeded the maximum rating of the output CM board. May indicate a fault in the motor circuit or internal fault.		
Output CM Connection Fault	Cables to output current measurement (CM) boards disconnected. Power system down and check cable to output CM board.		X
Output Fault	High current as measured by the IGBT. Check for short circuit on output lines and load. Output IGBT desat protection triggers this fault.		
Output Overload	Indicates a large and sudden overcurrent on the output module. Check motor circuit for faults. The overcurrent may be of a very short duration that cannot be captured by amp meters. Ensure that 1.1.17 OVERLOAD DERATE ENABLE is set to YES. If an output filter is installed, verify it is wired correctly.	X	
Over Temperature	Internal temperature of IGBT has exceeded 113°F. Reduce ambient temp. Check fan operation and ventilation openings for obstruction. Ensure that 1.1.19 OVER TEMPERATURE DERATE ENABLE is set to YES.	X	
PLL Fault (Phase Lock Loop)	Unable to lock onto the frequency of incoming power. Caused by grid distortion, unstable frequency, or an undersized generator. Cycling power OFF/ON can clear the fault if caused by an isolated incident.		
Sensor Connection Fail	4-20mA or 10VDC analog signal is not present on Control Terminals. This could indicate failure of the analog sensor or a disconnected sensor cable.		
Temp Sense Fault	Temperature sensor on the IGBT has failed or its cable is disconnected. Turn power off and check cables to IGBTs.		
Under Current	Motor current has fallen below the value set by parameter 1.1.10 UNDER CURRENT . Commonly used to detect a dry well condition.	X	

1 = Fault may be related to an adjustable parameter. Always check the value of the parameter to eliminate nuisance tripping.

2 = No automatic restarts allowed. The drive has shut down due to a potentially dangerous condition. Drive will remain OFF until fault is cleared. Turn power off and troubleshoot the system before restarting.

9.3 Fault Log

- The Fault Log records the number of times a particular fault has occurred. To access the Fault Log, press the HOME key and arrow up until, **6 FAULT LOG**, appears.
- Press ENTER key to access the list of faults. The Fault Log will continue to log the number of faults that have occurred until it is reset through the Main Menu item **5 RESTART LOG** or **7 CLEAR MEMORY**. The Fault Log is not to be confused with the restart counter.
- The restart counter is associated with the automatic restart function and is reset whenever the input power is cycled OFF/ON.

Table 32 – Troubleshooting

PROBLEM	POTENTIAL CAUSE	POSSIBLE SOLUTION(S)
Unit does not power up	Circuit breaker tripping	If incoming circuit breaker continually trips when VFD starts, the breaker and cable sizes should be sized by a certified electrician. Consider increasing breaker size.
Motor not running	Is a fault code indicated?	Based on the fault code, resolve any factors that are likely causing the fault. Clear the fault by pressing ENTER on the keypad or by cycling input power OFF/ON.
	Are the remote AUX switches closed?	Check the status of the switches or jumpers connected to AUX1 and AUX2 on the Control Terminals. The LCD display indicates the status of AUX terminals in the default display mode. All AUX terminals must be set to ON for the motor to run in AUTO mode.
	Are the signals to the Control Terminals corrupted?	Shielded cable is required for AUX terminal switch leads longer than 20 ft. Regular wire will induce capacitance in the line and corrupt control signals. Shielded cable is recommended for all control signal cables.
	Is the keypad in MAN or OFF mode?	The keypad will override signals on the Control Terminals when MANUAL mode is selected. Keypad must be in AUTO mode for external control signals to control the motor.
	Is MAX FREQUENCY set to 0 Hz?	Check the parameter 1.1.2 MAX FREQUENCY .
	Are the input terminals energized?	Check the input circuit breaker and fuses.
Motor is turning the wrong direction	Phase sequence on output terminals U, V, W is out of order	Swap any two of the three motor leads on the output terminals OR use parameter 1.1.6 REVERSE ROTATION via keypad.
Real Time Clock (RTC) clearing or not providing fault time stamps	Dead battery	Replace CR2032 battery, located on the Interface control board to the left of the graphic display.

10 Maintenance

The unit should be inspected and cleaned at least annually or more frequently if it is in an excessively warm, salty, or dusty environment.

- **Visual Inspection:**
Check for any signs of physical damage, discoloration, burnt components, or loose wiring. This helps identify potential issues early before they lead to failure.
- **Cleaning:**
Remove dust, dirt, and debris from cooling fans, heatsinks, and vents. Proper cooling is vital to prevent overheating and ensure the VFD operates within its specified temperature range.
- **Cooling System Check:**
Verify that cooling fans are operational and airflow pathways are unobstructed. Efficient cooling prolongs the life of internal components.
- **Electrical Connection Tightening:**
Inspect and tighten all electrical connections, terminals, and grounding points. Loose connections can cause arcing, overheating, or faults.
- **Monitor Operating Parameters:**
Observe the VFD's display and check for error codes, warnings, or abnormal readings. Early detection of issues allows for timely intervention.
- **Check Control Wiring and Sensors:**
Ensure that control wiring, sensors, and communication cables are intact and functioning correctly. Faulty sensors or wiring can affect VFD performance.
- **Firmware and Software Updates:**
Update the VFD's firmware as recommended by the manufacturer to improve functionality, security, and compatibility.
- **Input and Output Voltage Verification:**
Periodically measure input power and output voltage to confirm proper operation and detect any anomalies.
- **Filter Inspection and Replacement:**
Check any input/output filters and replace them if clogged or damaged to maintain power quality and reduce electrical noise.
- **Safety Checks:**
Confirm that all safety features, such as emergency stop functions and protective covers, are in place and operational.

11 Warranty Policy

Limited Warranty

Phase Technologies warrants to our customer the products listed herein will be free from defects in material and workmanship from the date of purchase by the original purchaser through the end of the of the warranty period. This warranty covers both parts and labor incurred by Phase Technologies, or an authorized Phase Technologies Service Technician. Phase Technologies obligations under this limited warranty, are limited to repair or replacement, at its sole discretion. All work will be performed at no charge for any part(s) or product found by Phase Technologies to be faulty during the warranty period. The warranty repairs must be performed by/at a Phase Technologies Authorized Service Center or at Phase Technologies, LLC headquarters in Rapid City, SD, in order to qualify for warranty coverage.

Obligations of Customer

- The original Sales Order must be presented to obtain "in-warranty" service.
- Any products returned to Phase Technologies must follow the [Phase Technologies RMA Procedure](#).
- Transportation of RMA products is the responsibility of the customer.
- Installations must comply with all national and local electrical codes.
-

Exclusions of the Warranty

This warranty does not cover any of the following: accident, misuse, fire, flood, and other acts of God, nor any contingencies beyond the control of Phase Technologies, LLC, including, but not limited to, water damage, incorrect line voltage, improper installation, missing or altered serial numbers, and service performed by an unauthorized facility. Phase Technologies' liability for any damage caused in association with the use of Phase Technologies' equipment shall be limited to the repair or replacement of Phase Technologies' equipment and will not extend to any incidental, special, indirect or consequential damages No person, agent, distributor, dealer, or company is authorized to modify, alter, or change the design of this merchandise without express written approval of Phase Technologies, LLC.

Additional/premium warranty coverages are provided for specific products, including but not limited to, the [PTCCP](#) and Phase Perfect [RPG](#). Proof of additional coverage must be presented by the customer.

Forum Selection

Any suit, claim, or cause of action arising from this document or any Phase Technologies product, will be governed by the laws of the State of South Dakota. Jurisdiction and venue for all disputes will be in the federal or state courts of South Dakota.

See <https://www.phasetechnologies.com/support/warranty>

12 Appendix A – Constant Pressure Wizard

MAINTAINING CONSTANT PRESSURE

Overview

Constant pressure pump systems play a critical role in maintaining stable pressure in various applications, such as water distribution, irrigation, and industrial processes. The efficient operation of these systems involves a balance between maintaining the desired pressure levels and allowing the pump to rest during periods of low demand. This guide addresses the challenge of pumping “sleeplessness” in constant pressure systems and offers insights into identifying the underlying causes and implementing practical solutions.

Cases of a Pump Not Going to Sleep

Several factors can contribute to the failure of a pump to enter the sleep mode in a constant pressure system.

- 1. Leaks in the System:**
 - ▶ Leaks in the system can create a constant demand on the pump, preventing it from reaching the required pressure level for sleep mode activation.
- 2. Excessive Head on the Pump:**
 - ▶ High head conditions can lead to the pump continuously operating at full capacity, making it difficult to achieve the pressure threshold necessary for entering sleep mode.
- 3. Steep Pump Curve:**
 - ▶ A pump with a steep performance curve may struggle to maintain the desired pressure range efficiently, causing it to stay active instead of entering sleep mode.
- 4. High Flow Centrifugal Pumps:**
 - ▶ Centrifugal pumps designed for high flow scenarios might have challenges building up the necessary pressure to activate sleep mode, leading to continuous operation.



Mitigation Strategies

To address the issue of pump sleeplessness, several effective mitigation strategies can be implemented. The following parameters can be found in: Change Parameter Values > Constant Pressure Parameters and Change Parameter Values > Operating Parameters

- 1. Finding and Fixing Leaks:**
 - ▶ Far and away the most important first step is to detect and repair any leaks in the system to reduce unnecessary demand on the pump and enable sleep mode activation.
- 2. Adjusting Shutoff Frequency:**
 - ▶ Increasing the shutoff frequency of the VFD can help reduce the time it remains operational, allowing it to enter sleep mode more consistently.
- 3. Lowering PSI Setpoint:**
 - ▶ Lowering the pressure setpoint can decrease the demand on the pump, making it easier for the system to achieve the required pressure for the pump to go to sleep.
- 4. Increase Minimum Frequency:**
 - ▶ Increase Min Frequency 2 Hz above the system's deadhead frequency.
- 5. Adding Boost: X** Incorporating a boost amount, such as 3 - 5 psi, will increase pressure above the setpoint allowing a larger window for the drive to stay asleep, preventing short cycling.
- 6. Increase Integral Gain: X** Integral Gain controls the overall reaction time of the VFD. Increasing the gain will allow the drive to react quicker to pressure changes and allow it to enter sleep mode.

Conclusion

The efficient operation of constant pressure pump systems depends on the proper activation of sleep mode during periods of low demand and frequency. By understanding the causes of pump sleeplessness and implementing appropriate mitigation strategies, system operators can enhance energy efficiency, prolong pump life, and ensure consistent performance.

LHX / DXL CONFIGURATION WIZARDS

System Configuration = 0

▶ Basic RUN/STOP operation

This is the factory default configuration for basic operation of the drive that allows RUN/STOP control of the motor in AUTO mode using a dry contact on AUX1 and/or AUX2.

System Configuration = 1

▶ Analog Constant Pressure

Use this setting to operate analog constant pressure systems with a 4-20 mA transducer.

System Configuration = 2

▶ Analog Constant Pressure with A redundant sensor and up to two PSI Setpoints

This configuration allows the use of two 4-20 mA transducers.

System Configuration = 3

▶ Analog Constant Pressure with redundant sensors and up to four PSI Setpoints

This configuration allows the use of two 4-20 mA transducers.

System Configuration = 4

▶ Speed Reference I1

Use this setting for motor speed control by an external 4-20 mA source connected to the I1 Control Terminals.

System Configuration = 5

▶ Speed Reference I2

Use this setting for motor speed control by an external 4-20 mA source connected to the I2 Control Terminals.

System Configuration = 6

▶ Speed Pot Control

Use this setting for motor speed control by a potentiometer or an external 0-10 VDC source connected to the 0-10 VDC Control Terminals.

System Configuration = 7

▶ Analog Constant Pressure with HOA and Speed Potentiometer

This setting allows the user to either turn the motor off, control motor speed with a potentiometer, or operate in analog constant pressure mode using an HOA switch.

System Configuration = 8

▶ Analog Constant Pressure Swap Sensors

This configuration allows the use of two 4-20 mA transducers.

System Configuration = 9

▶ HOA Speed Reference Selector

This configuration allows multiple speed references to be used.

System Configuration = 10

▶ Pump Down Open Loop

This configuration determines pump speed based on fluid level as measured by a 0-10 VDC or 4-20 mA transducer.

System Configuration = 11

▶ HOA only

HAND – will allow the system to operate at max frequency without any control signal.

OFF – will not allow the output of the drive to be energized.

AUTO – will allow the system to be operated with a control signal.



See *LHX Series / DXL Series operation and installation manual* for details on system configuration setup.

SYSTEM CONFIGURATION = 0

► Basic RUN/STOP operation

LHX / DXL SERIES

Control Board v3.0

Description

This is the factory default configuration for basic operation of the drive that allows RUN/STOP control of the motor in AUTO mode using a dry contact on AUX1 and/or AUX2.

Application Usage

- Float Switch
- Pivot Relay
- Start/Stop Signal

Pro Tips

AUX 1 and 2 must be "ON (Closed)" for the system to run

To check the state of your Auxiliaries, navigate to 3.19 and 3.20 in Read Measured Values

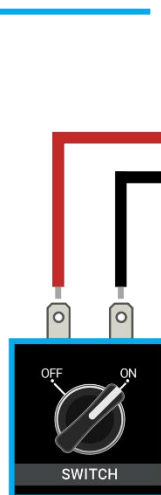
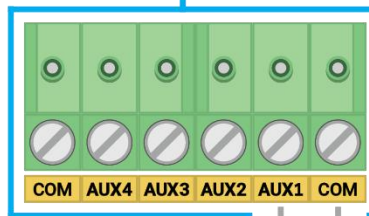
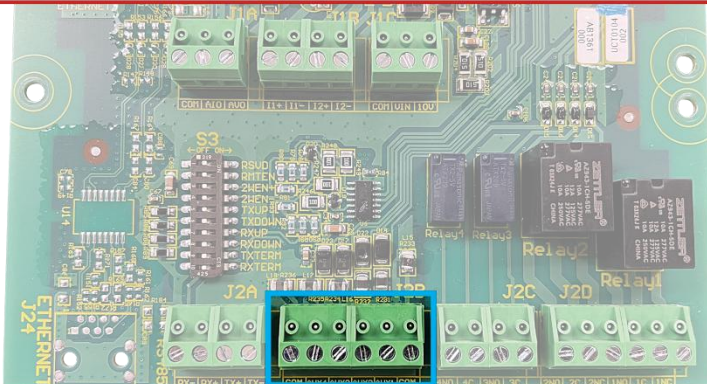

Switch #1

SYSTEM CONFIGURATION = 1

► Analog Constant Pressure

LHX / DXL SERIES

Control Board v3.0

Description

Use this setting to operate analog constant pressure systems with a 4-20 mA transducer.

Application Usage

- Simple Constant Pressure

Pro Tips

AUX 1 and 2 must be "ON (Closed)" for the system to run

To check the state of your Auxiliaries, navigate to 3.19 and 3.20 in Read Measured Values

To check the quality of your analog signals, navigate to 3.22 in Read Measured Values

At zero PSI on the system the analog signal should be 3.8-4.2mA

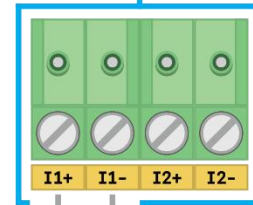
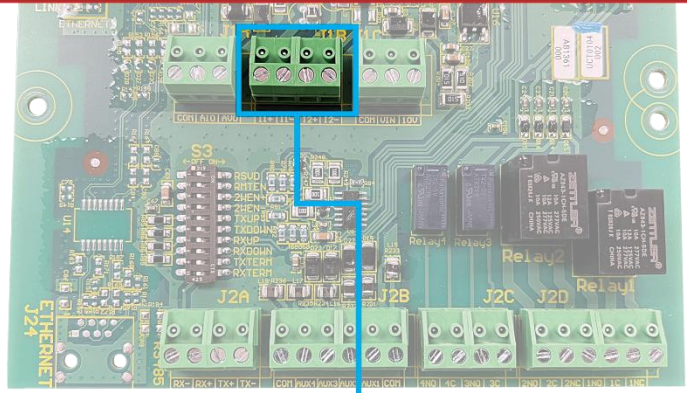

Transducer #1

SYSTEM CONFIGURATION = 2

► Analog Constant Pressure with a redundant sensor and up to two PSI Setpoints

LHX / DXL SERIES

Control Board v3.0

Description

This configuration allows the use of two 4-20 mA transducers.

AUX3	PSI Setpoint
Off	1
On	2

Application Usage

- Multiple Setpoints

Pro Tips

AUX 1 and 2 must be "ON (Closed)" for the system to run

To check the state of your Auxiliaries, navigate to 3.19 and 3.20 in Read Measured Values

I1+ and I1- will always be the primary sensor. Navigate to 1.4.1 to program PSI Setpoint 1

I2+ and I2- will automatically take over control should the primary sensor fail. Navigate to 1.4.2 to program PSI Setpoint 2

To toggle between setpoints without programming AUX 3 each time, install an on/off switch as shown.

To check the quality of your analog signals, navigate to 3.22 in Read Measured Values

At zero PSI on the system the analog signal should be 3.8-4.2mA

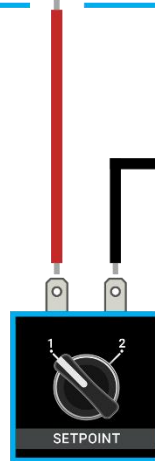
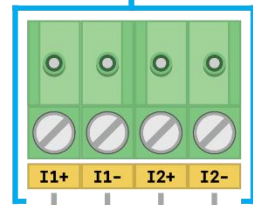
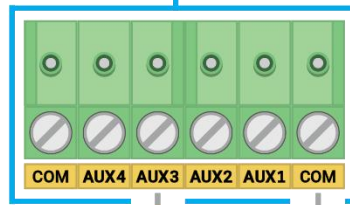
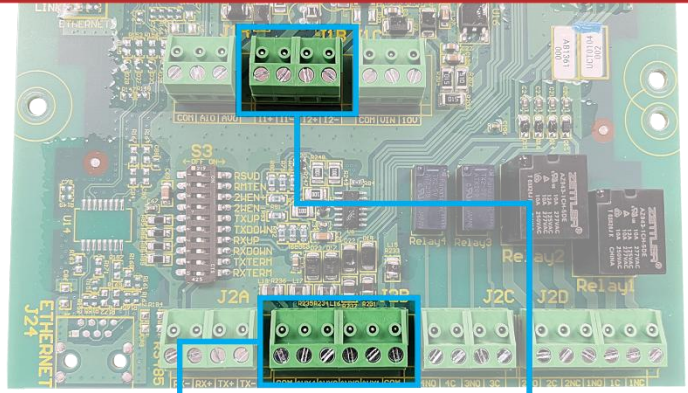

Switch #1



Transducer #1



Transducer #2

SYSTEM CONFIGURATION = 3

► Speed Reference I1

LHX/DXL SERIES

Control Board v3.0

Description

Use this setting for motor speed control by an external 4-20 mA source connected to the I1 Control Terminals.

Application Usage

- PLC Control
- HVAC

Pro Tips

AUX 1 and 2 must be "ON (Closed)" for the system to run

To check the state of your Auxiliaries, navigate to 3.19 and 3.20 in Read Measured Values

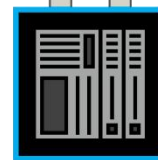
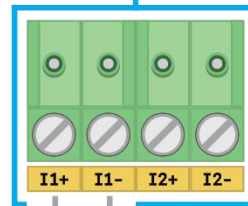
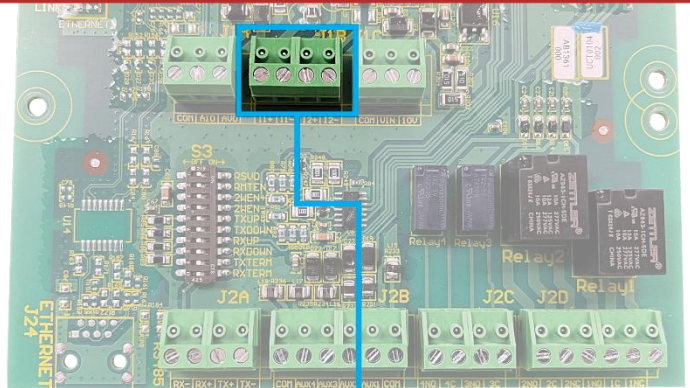

PLC Control
(4-20 mA Input)

SYSTEM CONFIGURATION = 4

► Speed Reference I2

LHX / DXL SERIES

Control Board v3.0

Description

Use this setting for motor speed control by an external 4-20 mA source connected to the I2 Control Terminals.

Application Usage

- PLC Control
- HVAC

Pro Tips

AUX 1 and 2 must be "ON (Closed)" for the system to run

To check the state of your Auxiliaries, navigate to 3.19 and 3.20 in Read Measured Values

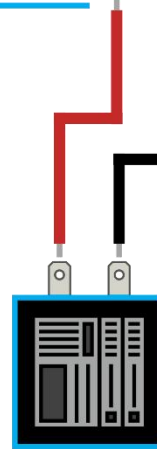
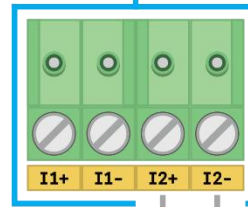
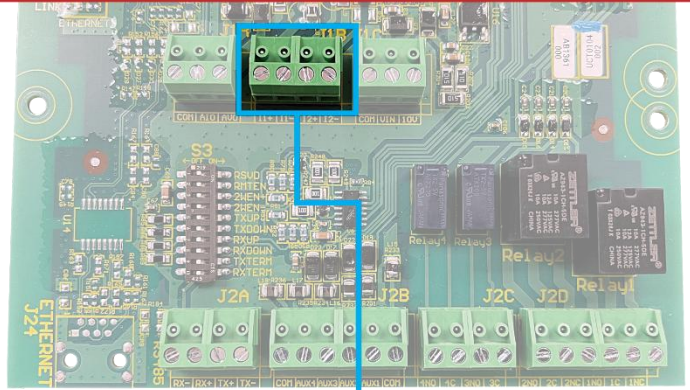

PLC Control
(4-20 mA Input)

SYSTEM CONFIGURATION = 5

► Speed Pot Control

LHX / DXL SERIES

Control Board v3.0

Description

Use this setting for motor speed control by a potentiometer or an external 0-10 VDC source connected to the 0-10 VDC Control Terminals.

Application Usage

- PLC Control
- HVAC
- Manual Speed Control

Pro Tips

AUX 1 and 2 must be "ON (Closed)" for the system to run

To check the state of your Auxiliaries, navigate to 3.19 and 3.20 in Read Measured Values

1.1.1 Min Frequency default is 30Hz. For speed control across the full scale change 1.1.1 to 5Hz

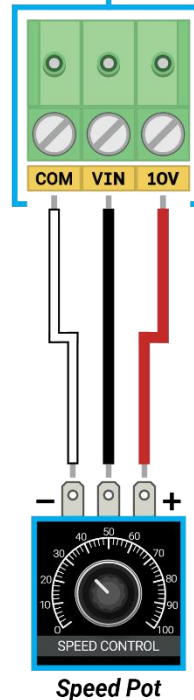
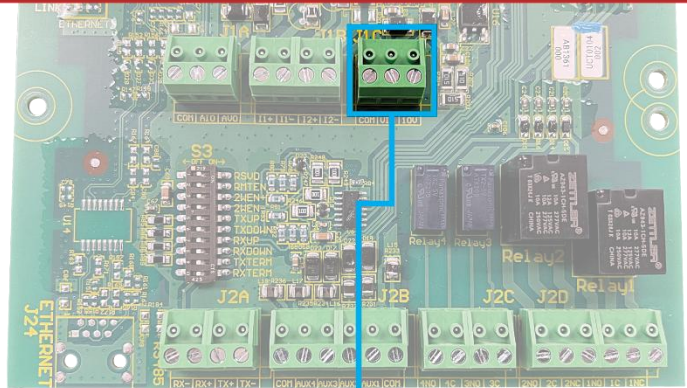

SYSTEM CONFIGURATION = 6

► Analog Constant Pressure with HOA and Speed Potentiometer

LHX / DXL SERIES

Control Board v3.0

Description

This setting allows the user to either turn the motor off, control motor speed with a potentiometer, or operate in analog constant pressure mode using an HOA switch.

AUX3	Function
Off	Analog Constant Pressure
On	Speed Control

Application Usage

- **Constant Pressure** - with Optional Manual Speed Control

Pro Tips

AUX 1 and 2 must be "ON (Closed)" for the system to run

To check the state of your Auxiliaries, navigate to 3.19 and 3.20 in Read Measured Values

An HOA switch does the same thing as your "Manual" button on the keypad. Careful pushing the "Manual" button on your keypad, it will still change the state of your auxiliaries.

To check the quality of your analog signal, navigate to 3.22 in Read Measured Values

At zero PSI on the system the analog signal should be 3.8-4.2mA

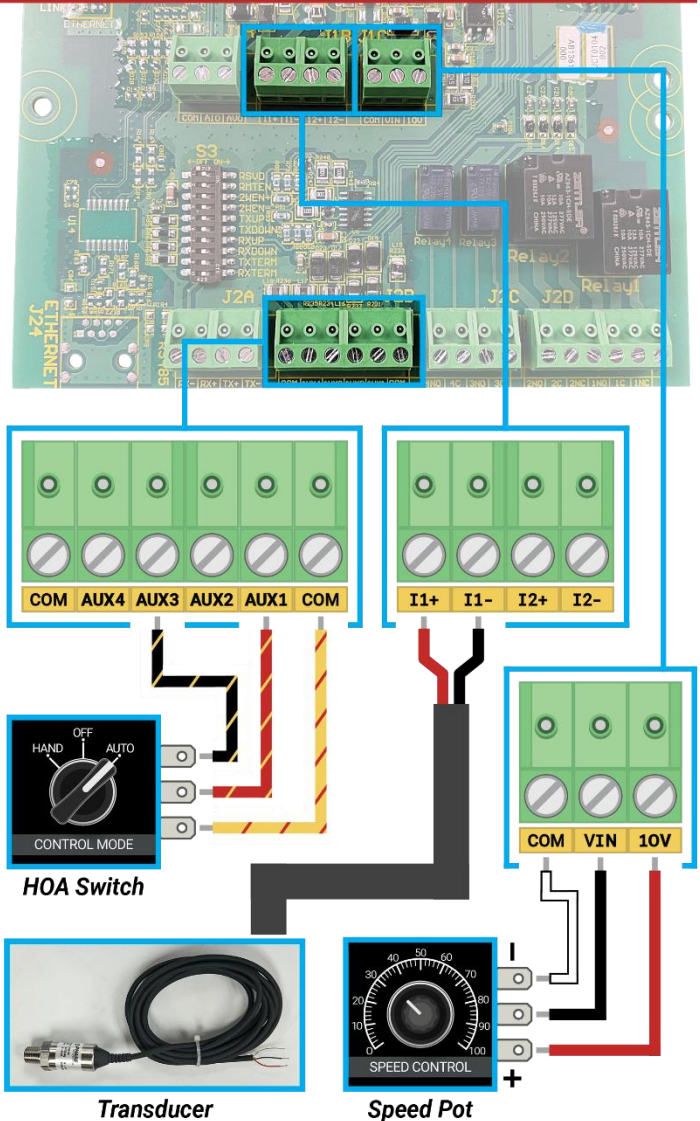

SYSTEM CONFIGURATION = 7

► Analog Constant Pressure Swap Sensors

LHX / DXL SERIES

Control Board v3.0

Description

This configuration allows the use of two 4-20 mA transducers.

AUX3	PSI Setpoint
Off	Analog Constant Pressure
On	Backup Sensor

Application Usage

- Multiple Zones

Pro Tips

AUX 1 and 2 must be "ON (Closed)" for the system to run

To check the state of your Auxiliaries, navigate to 3.19 and 3.20 in Read Measured Values

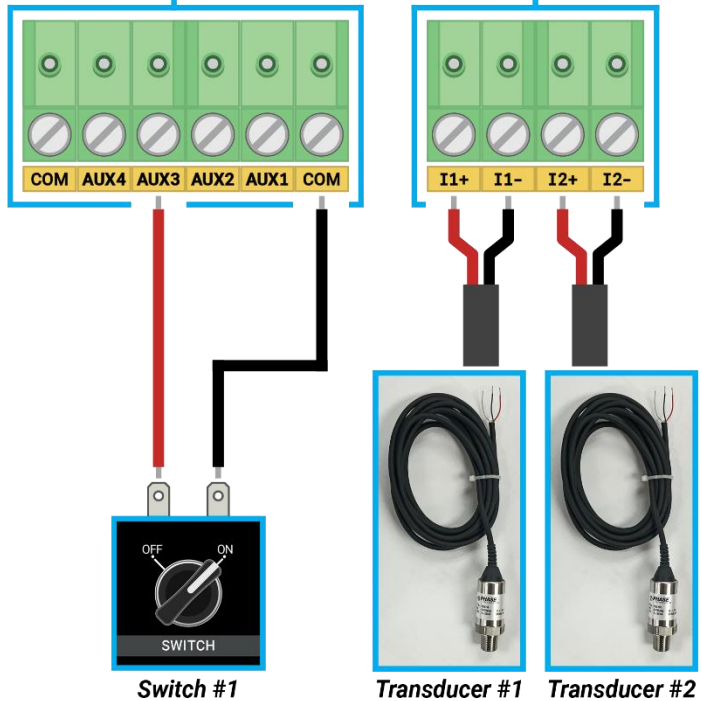
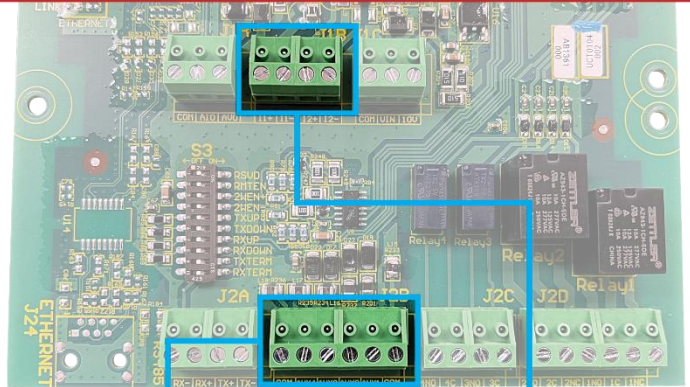

SYSTEM CONFIGURATION = 8

► HOA Speed Reference Selector

LHX / DXL SERIES

Control Board v3.0

Description

This configuration allows multiple speed references to be used.

AUX1	AUX3	PSI Setpoint
On	On	0-10 VDC Speed Reference
On	Off	I1 4-20 mA Speed Reference

Application Usage

- **Speed Control - with Backup Speed Reference**

Pro Tips

AUX 1 and 2 must be "ON (Closed)" for the system to run

To check the state of your Auxiliaries, navigate to 3.19 and 3.20 in Read Measured Values

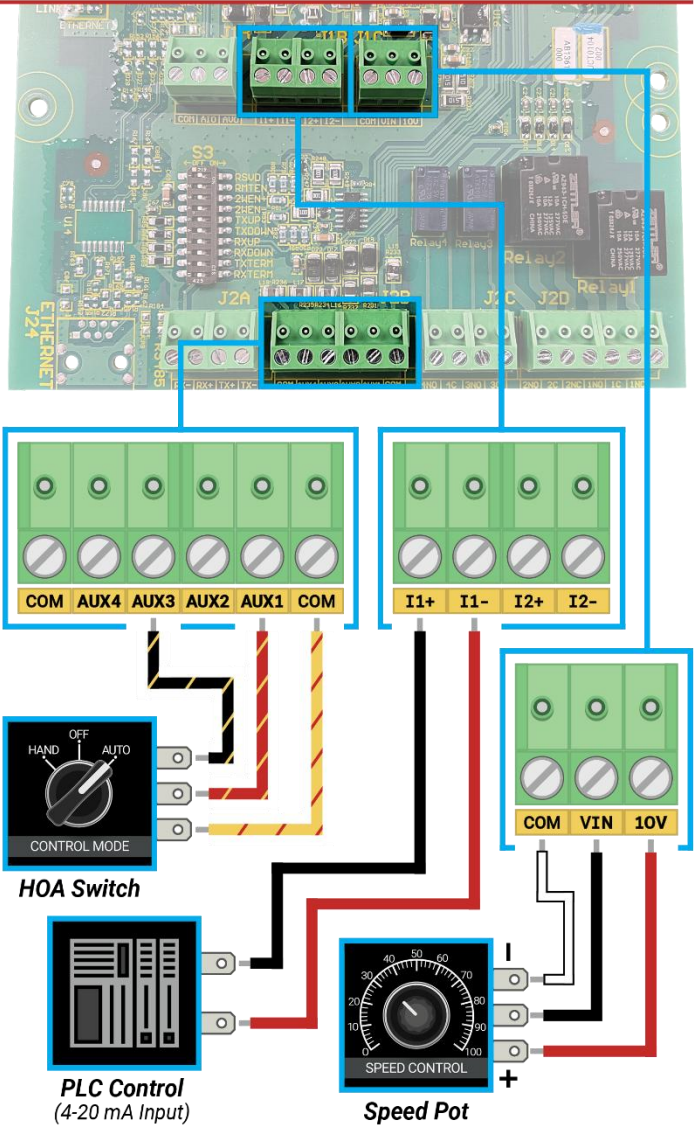

LEAD/LAG SETUP GUIDE

Intro

Constant pressure systems requiring a significant range of flow are good candidates for using a Lead/Lag setup. Lead/Lag refers to a master VFD dictating when a lag pump is staged in to maintain a specific pressure. Duplex/Triplex is similar to Lead/Lag with the added function of switching the primary pump at set clock time intervals.

Lead/Lag

Connect 16–22 AWG control wire from 1NO and 1C from the master to AUX1 and COM of up to 2 Slave VFDs on the SD Series and up to 4 on the 1LH, 3LH, and DX Series. Make sure each individual VFD has its own transducer (if maintaining constant pressure or speed) and is individually set up for the intended application. There can be applications where the lag pump is simply on/off and a sensor not present.

Step 1: Set **AUX1 Select** to **0 = RUN/STOP** on all slave units in Interface Parameters.

Step 2: Set **Number Lag Pumps** = to the number of lag pumps in Lead/Lag Parameters.

With these two steps complete, the Lead/Lag setup will be operational using default settings.

Figure 1

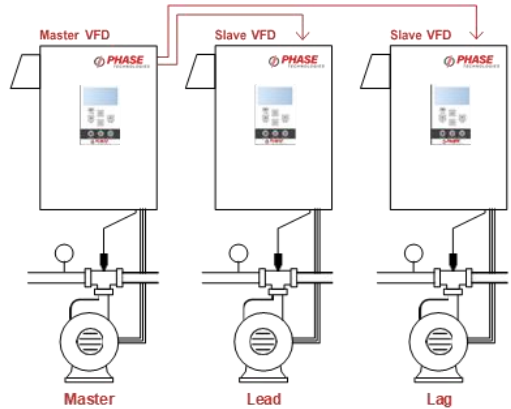
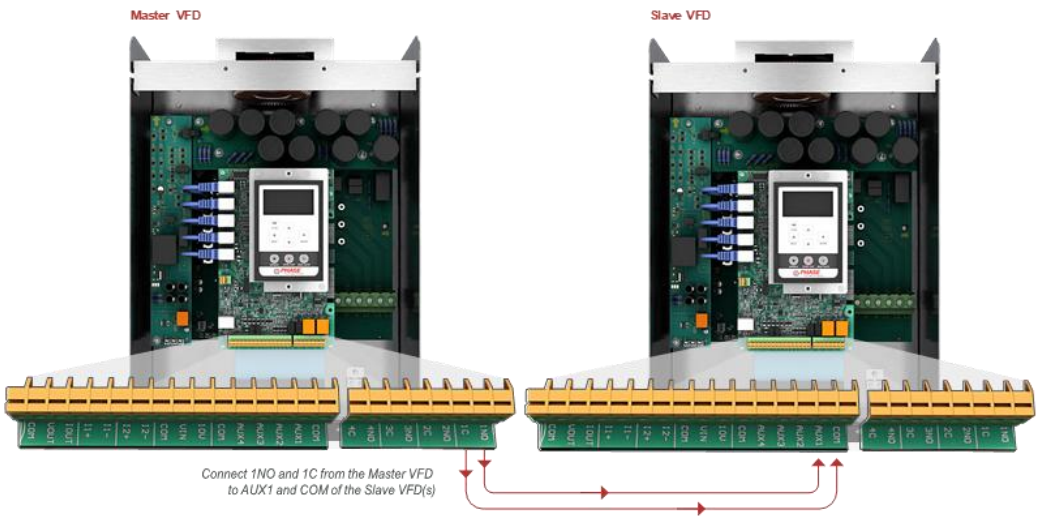

Figure 2



Connect 1NO and 1C from the Master VFD to AUX1 and COM of the Slave VFD(s)

15 Appendix D – Multiplex Over Modbus Setup Guide

Introduction

Multiplex refers to a primary VFD that controls secondary VFDs. These VFDs can be alternated after set time periods to evenly wear pumps or be used for Lead/Lag to cover a wide range of flow conditions.

DIP Switch Settings

Duplex panels from the factory should have DIP Switches preset and will not require setting DIP switches as described below.

On the control boards of all systems that will be multiplexed together, locate the DIP switch array labeled “S2” and turn DIP switch 6 to the ON position. Next locate the DIP switch array labeled “S3” and turn switches 3 and 4 to the ON position. See image below for DIP switch array locations.

Communication Wiring

Duplex panels from the factory should come pre-wired and will not require wiring as described below.

Connect wires between all systems intended for multiplex by wiring all RX- terminals together and all RX+ terminals together. Also short one of the COM terminals of the primary VFD to one of the COM terminals of each secondary VFD.

Primary VFD Setup

1. Determine which VFD will act as the primary and use its keypad to walk through the Constant Pressure Wizard.
2. Next, navigate to 1.3.2 MENU COMPLEXITY and press ENTER. Change this setting to ADVANCED and press ENTER to save the parameter. This unhide all menu items.
3. Next, navigate to 1.6.1 MULTIPLEX SETUP and press ENTER.
4. Set MULTIPLEX TYPE to Modbus and press ENTER.
5. Set MULTIPLEX ID & DEFAULT ROLE to 1 – Primary and press ENTER.
6. Set the MULTIPLEX CYCLE TIME to the amount of time each pump should run before cycling to the next pump. This value represents clock time, not pump run time. Press ENTER.
7. The SHARE TRANSDUCER MEASUREMENT parameter can be set to YES or NO, depending on the needs of the system. If each VFD will have its own pressure transducer, select NO. If only one pressure transducer will be used, it can be installed in any of the VFDs and this parameter should be set to YES. Press ENTER.
8. After completing the previous step, the screen will display, “Multiplex Setup 1 – Setup all systems until the wait screen then press Enter.” Now move on to programming the secondary VFDs.

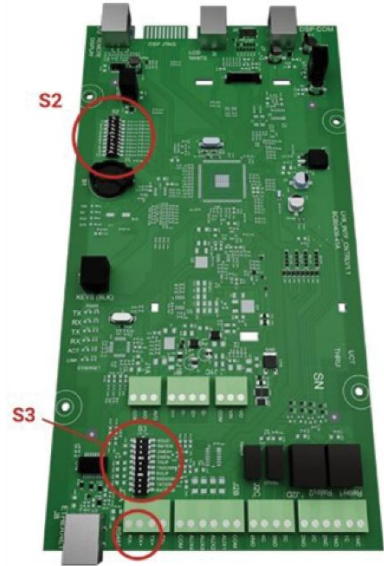

Multiplex Over Modbus Setup Continued

Secondary VFD Setup

1. Move to the secondary VFD and use the keypad to walk through the Constant Pressure Wizard.
2. Next, navigate to 1.3.2 MENU COMPLEXITY and press ENTER. Change this setting to ADVANCED and press ENTER to save the parameter. This unhides all menu items.
3. Next, navigate to 1.6.1 MULTIPLEX SETUP and press ENTER.
4. Set MULTIPLEX TYPE to Modbus and press ENTER.
5. Set MULTIPLEX ID & DEFAULT ROLE to 2 - Secondary and press ENTER.
6. The screen will now say "Multiplex Setup 1 – Waiting for Primary System."
7. If multiple secondaries will be used, repeat the Setup Secondary VFD process for all, choosing the subsequent number for MULTIPLEX ID & DEFAULT ROLE for each. (ie. 3 – Secondary, then 4 – Secondary, etc)

Finish Setup

1. After completing these steps on all Multiplex VFDs, return to the primary VFD and press ENTER.
2. The primary screen will say "Found S2" with numbering matching the chosen Multiplex ID's for secondary units. Press ENTER to confirm or UP to retry.
3. If all VFDs are communicating properly, the primary will say Programming Complete. Press the HOME button on all VFDs to return HOME.
4. Press the RUN/AUTO button on all VFDs to begin pumping.

16 Appendix E – Troubleshooting: Transducers

TRANSDUCER TROUBLESHOOTING GUIDE

Installation Guidelines *(using a Phase Technologies supplied transducer)*

1. Prepare transducer wire by keeping the shielding as close to the terminals as possible.
2. Clip the bare ground wire flush with the cable shielding. Do not hook to a grounding terminal.
3. Strip transducer + positive and - negative wires approximately 3/16" from the end.
4. Connect Red or White wire into I1+ and the Black wire into I1-.
5. Pull on each connection to confirm they are secure.
6. Power up the drive and navigate to Read Measured Values by pressing the HOME button, then the UP arrow. Press Enter and then use the UP arrow until the screen shows the following at 0 psi.
7. If the mA are less than 3.80 check connections. If they are secure, try swapping the transducer leads. Recheck input value.

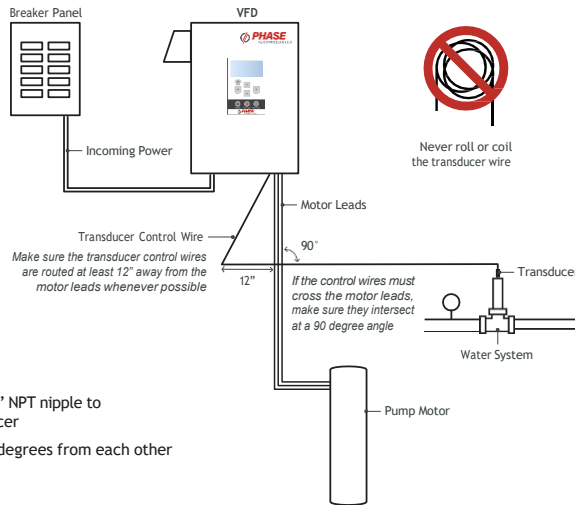
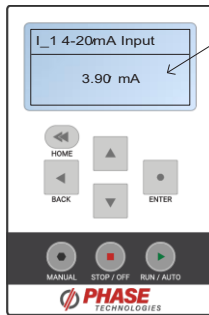
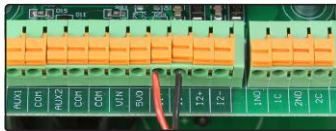

Common Issues

Do

- ▶ Use a 3" non-metallic "T" fitting or plastic 1/4" NPT nipple to prevent noise from coupling to the transducer
- ▶ Cross the transducer and motor leads at 90 degrees from each other whenever possible
- ▶ Always cut the transducer wire to length

Do Not

- ▶ Do not route the transducer wire in the same conduit or parallel to the motor leads
- ▶ We do not recommend splicing transducer wire. If a wire must be spliced the additional wire should be shielded and the splice must be a soldered connection. Do not use wire nuts.
- ▶ Never roll or coil the transducer wire.

Finally, if the transducer signal is still intermittent or unavailable, replace with a new Phase Technologies approved transducer.

Additional Notes:

1. Grounding for the VFD should be less than 4 Ohms to ground to limit noise in the VFD. (See Grounding Guide for details)
2. The pressure transducer should be a minimum of 12" from any joint, be placed between the well and any shut off valves (so you can't dead head), and not be placed directly on a check valve.